

# INSTALLATION AND OPERATION MANUAL

## X-50 LCG RECORDER



**LOWRANCE ELECTRONICS, INC.**  
12000 E. SKELLY DR., TULSA, OKLA. 74128

LITHO IN U.S.A.

988-0105-11 Rev. A

NOTES

-  
B.  
-

4

## TABLE OF CONTENTS

Installation	2
Power Connections	2
Temperature Sensor Installation	4
Noise	5
Keyboard Basics	6
Operation	8
On	8
Off	8
2nd	8
Clear	9
Auto	9
Sensitivity	9
Sensitivity—Automatic	10
Sensitivity—Manual	10
GRAYLINE	11
Chart Speed	12
Scale Markers	13
Range	14
Lower Limit—Automatic	14
Lower Limit—Manual	15
Upper Limit	15
Auto Range with Zoom Bottom Track	16
Digital	17
10th	19
Alarms	19
Zone Alarm	20
Clearing Zone Alarm	21
Note Key	21
Depth Alarm	21
Light	23
Discrimination	23
Temperature	24
Surface Clarity Control (SCC)	25
Speed	26
Log	27
Feet, Fathoms, Meters	27
Pulse	28
Preset	28
Display Memory	29
Command Key—MENUS	30
FASTRAK	31
Grayline Checkerboard/Lines	32
Speaker Volume	32
Clear Distance Log	32
Narrow/Wide Auto Range Window	32
Digital Averaging	33
Battery Backup	33
Scale On/Off	33
Calibrate Speed	33
Test Pattern	34
Keel Offset	35
Total System Reset	36
Transducers and Cone Angles	36
Signal Interpretation	37
Fish Signals	38
Water Temperature and Thermoclines	39
Surveying a Lake	40
Bait Fish	40
How to Obtain a Schematic	41
Specifications	41

The Lowrance X-50 Liquid Crystal Sonar (LCG) is the most sophisticated and reliable instrument of its kind. Its high resolution display gives the sharpest definition ever. This unit is so advanced, you can just press the "ON" button and let it do all the work. However, taking manual control enables you to open up a whole world of features not available in other sonars.

To get started with your X-50, first read the installation section. This is where it all begins, and improper installation can cause problems down the road. After you've read these instructions and installed your X-50, read the rest of this manual in detail. The more you know when you get to the water, the more your X-50 will do for you.

## **INSTALLATION**

### **Mounting**

The X-50 can be installed in any convenient location, provided there is clearance when tilted for the best viewing angle. Holes in the bracket base allow wood screw or through bolt mounting. The bracket can be attached to aluminum panels with sheet metal screws. However, we suggest placing a piece of plywood on the back of thin fiberglass panels to secure the mounting hardware. Make certain there is enough room behind the unit to attach the power and transducer cables.

A one inch hole in the base of the gimbal bracket allows the power and transducer cables to be routed up through the mounting surface. After the cables have been routed, the hole can be filled with silicone rubber adhesive (RTV) to prevent water leaks.

### **Power Connections**

The X-50 operates from a 12 volt battery system. The power cable can be attached to an accessory or power buss, but if you have problems with electrical interference (random dots or lines that show whenever the boat's engine or an accessory is on), then attach the cable directly to the battery.

The power cable has two sets of cables. One set has the red power and black ground wires for connection to the 12 volt battery system. The other has a connector for the temperature probe and the optional speed sensor. See the owner's manual enclosed with the LSS-5 speed sensor for installation instructions.

NOTES

The power cable has two wires, red is the positive lead and black is negative or ground. An in-line fuse holder containing a 4 amp fuse is supplied with the X-50. This attaches to the red wire on the power cable with the crimp connector. The other end of the fuse holder attaches to the battery or accessory buss. If the cable is not long enough, splice ordinary #18 gauge wire onto it. Be certain that the fuse holder is as close to the power source (battery or accessory buss) as possible. This protects the power cable and your X-50 in the event of a short. The X-50 is protected from accidental polarity reversals and will not be harmed if the wires are reversed. (However, the unit will not work until the correct polarity is applied.)

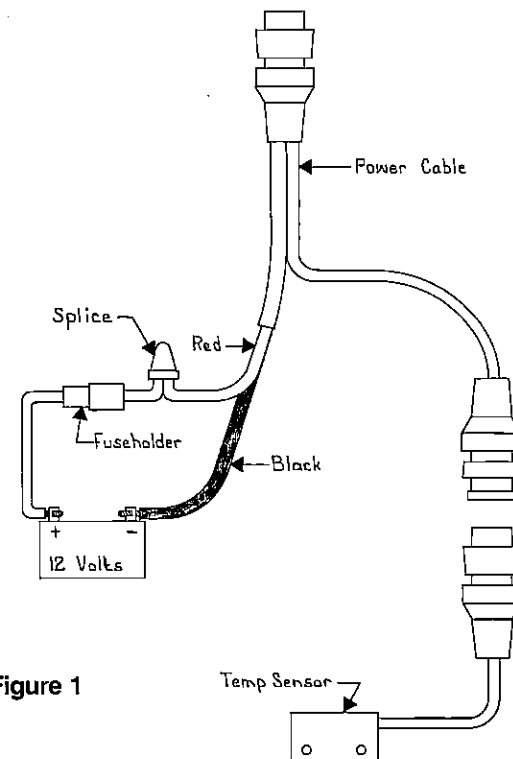

Figure 1

Temp Sensor

## TEMPERATURE SENSOR INSTALLATION

The temperature sensor should be mounted in a location that allows contact with the water at all times. The diagram in Figure 2 shows a typical location. Once a suitable place is found, mount the sensor to the hull with two #8 stainless steel screws. Above the water line drill a 3/4" hole for the connector to pass through. Route the cable via the shortest path to the X-50's power cable. Plug the sensor's cable into the in-line connector on the X-50's power cable. NOTE: If the speed sensor is also installed, plug the temperature sensor into the speed sensor's in-line connector, then attach the speed sensor's plug to the in-line connector on the X-50's power cable. See figure 3 for details.



Figure 2

TEMPERATURE SENSOR

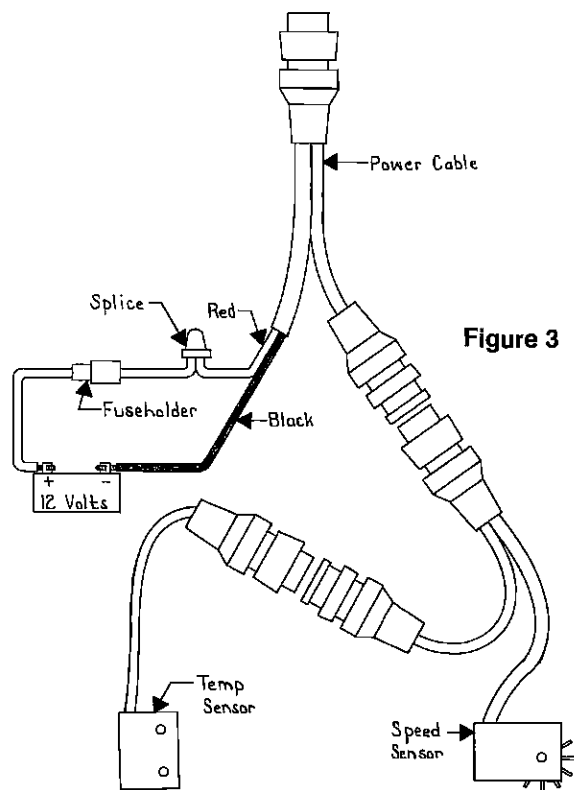

Figure 3

## SPECIFICATIONS

Dimensions .....	7"H x 8.8"W x 3.7"D
Weight .....	2.6 pounds
Transmitter .....	192 kHz
Output Power (typical) .....	3000 watts (peak to peak) 375 watts (RMS)
Receiver Sensitivity .....	90 db
Operating Current .....	500 ma
Operating Voltage .....	9-15 vdc
Number of Pixels .....	192 vertical 64 horizontal 12,288 total

The temperature of water in the lake is seldom constant from top to bottom. Layers of different temperatures form, and the junction of a warm and cool layer of water is called a thermocline. The depth and thickness of the thermocline can vary with the season or time of day. In deep lakes there may be two or more at different depths. Thermoclines are important to fishermen because they are areas where fish are active. Many times bait fish will be above the thermocline while larger game fish will suspend in or just below it.

The X-50 can detect this invisible layer in the water, but the sensitivity will probably have to be turned up to see it.

A knowledge of the water temperatures various fish prefer, and in which they usually remain, helps you get the most from your X-50.

## **SURVEYING A LAKE**

The most successful anglers on any lake or reservoir are those who fish it day after day and year after year until they learn the hot spots that produce fish consistently. They discover through experience where, and at what depth, they can expect to find the kind of fish they want at any season. And they realize that these productive areas change throughout the year depending on water level, temperature, food, and other factors.

With the aid of the X-50, anyone can eliminate guesswork and concentrate on the areas where fish are likely to be—even if it's the first time on the lake!

The most efficient way to become acquainted with a body of water is to survey it with your X-50. Start out with a map of the lake, if possible, and indicate the promising spots in relation to landmarks on shore.

Keep a few Lowrance Fish-N-Floats in the boat, ready to toss overboard. When the X-50 indicates a school of fish, throw the buoy out. The string will unwind until the sinker hits bottom. Then, because of the marker's flat shape, it won't unwind any further. With the school thus marked, you can make your turn and come back to fish in exactly the right spot. This is essential when you're far from shore on a big lake. Unless you mark the school of fish when you're over it, you may not be able to find it again.

## **BAIT FISH**

The importance of bait fish to successful fishing can't be overemphasized. They are the principle food of all game fish in most waters.

Bait fish are the plankton feeding forage fish, such as minnows and shad. Bait fish can also be the young of game fish, such as crappies, bluegill, and bass.

Most bait fish are concentrated within five feet of the surface where sunlight promotes the growth of the plankton on which they feed. One method of fishing is to use the X-50 to find the bait fish first. A school of bait fish will look like a "cloud" on the X-50's display. Usually, game fish will be nearby, often directly beneath the school of bait fish.

## **TRANSDUCER**

Installation instructions for the transducer are supplied with the transducer in a separate package. Please read the instructions carefully before you start installing the transducer.

## **NOISE**

Electrical noise picked up by the power cable can be minimized by routing it away from other possible sources of electrical interference. One of the largest noise generators is the engine's wiring harness that runs from the engine to the instrument panel. This harness usually contains a wire for the tachometer which radiates RF (radio frequency) energy. For best results, keep the power and transducer cables away from the engine wiring. Also, bilge pump wiring can sometimes radiate noise so try to keep the X-50's cables away from those wires.

VHF radio antenna cables radiate RF energy at higher power levels than even the engine's wiring harness. It is very important to keep the X-50's power and transducer cables as far away as possible from VHF radio antenna cable.

If there is no noise—interference—on the unit when the boat is sitting still with the engine running in neutral, but interference begins at slow boat speeds, worsening as the boat speed increases, then a probable cause is acoustic noise, or cavitation. This noise is not electrical, but rather mechanically induced noise from the transducer. Usually, acoustic noise is created by air bubbles passing over the face of the transducer. As a boat travels faster, more air bubbles are created which generate noise on the display. To eliminate this problem, read the transducer owner's manual for proper mounting techniques.



## KEYBOARD BASICS

**SENSITIVITY** These keys control the graph's sensitivity. The digital's sensitivity is always automatically adjusted, while the graph's sensitivity is automatically adjusted when the X-50 is in Automatic. The receiver sensitivity has 31 steps which allows adjustment for a wide range of conditions. The left arrow key decreases the sensitivity, the right arrow key increases it.

**ZONE ALARM** This group of keys control the X-50's zone alarm. It can be used as a "fish alarm" that will sound if fish or a school of fish enters the alarm zone. The bottom signal will also set off the alarm.

**0-9** These keys allow the entry of numbers 0 through 9. Some of these keys have more than one function (printed in white letters) and can be accessed using the 2nd key. When a numeric key is pressed, the number will be displayed in a window near the top center of the display.

**CLEAR** The CLEAR key erases the last key pressed. It can also erase other features, as will be seen later.

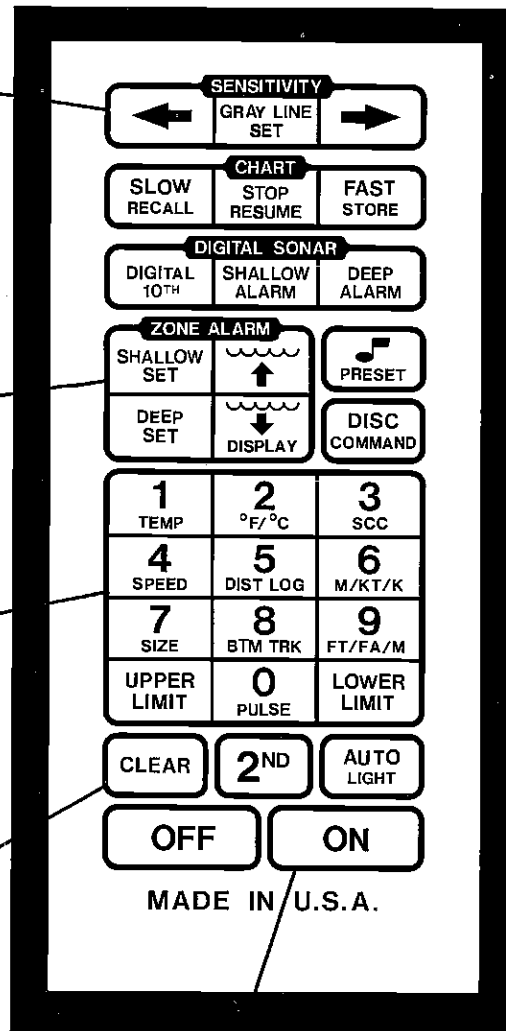

Figure 4

**OFF ON** These keys turn the X-50 off and on. To turn it on, simply press the ON key. To turn it off, press the OFF key. A beep will occur every time a key is pressed. This is the X-50's way of telling you that it has accepted a command.

If a partial arch occurs most of the time on your unit (the mark curves up, but not back down, or vice-versa) it could be the transducer is not pointed straight down. If the transducer is mounted on the transom, adjust it until the fish show the distinctive arch. This may take some trial and error until the correct mounting is achieved.

Remember, there must be some movement between the boat and the fish to develop the arch. Usually this means trolling at very slow speeds with the main engine in gear at a minimum throttle setting.

The depth of the water will affect the size and shape fish arch due to the cone angle diameter. For example, if the cone passes over a fish in shallow water, the signal displayed on the X-50 may not arch at all, due to the narrow cone diameter and the resolution limitations of the display.

Compared to a paper graph, an X-50 cannot show as fine of detail because the pixels (dots on the screen) are much larger than a paper graph's markings. Therefore, the X-50 cannot show fish arches as well as graph, and it requires a bit more work initially to read and interpret the screen than a paper graph.

Very small fish probably will not arch at all, while medium sized fish will show a partial arch, or a shape similar to an arch if they're in deep water. Large fish will arch, but the sensitivity needs to be tuned up in deeper water to see the arch. Because of water conditions, such as heavy surface clutter, thermoclines, etc., the sensitivity sometimes cannot be tuned high enough to get fish arches.

One of the best ways to get fish arches is to expand or "zoom" a segment of the water, for example 40 to 60 feet. The smaller the segment, the better the screen resolution will be. Then, turn up the sensitivity as high as possible without getting too much noise on the screen. In most water depths, this method should work to display fish arches.

## WATER TEMPERATURE AND THERMOCLINES

Water temperature has an important—if not controlling—influence upon the activities of all fish. Fish are cold blooded and their bodies are always the temperature of the surrounding water. During the winter, colder water slows down their metabolism so that they need about a fourth as much food as they consume in the summer.

Most fish don't spawn unless the water temperature is within rather narrow limits. To find the different temperatures, the X-50's surface temperature display is a valuable aid to your boat. This unit provides an extremely quick response to identifying the desired surface water spawning temperatures for various species. Trout can't survive in streams that get too warm; bass and other fish eventually die out when stocked in lakes that remain too cold during the summer. While some fish have a wider temperature tolerance than others, each has a certain range within which it tries to stay. Schooling fish suspended over deep water lie at the level that provides this temperature in which, we assume, they are the most comfortable.

## FISH SIGNALS

The signals displayed on the X-50 by fish can be identified by various shaped markings in certain patterns, as opposed to random marks created by noise, or the solid, continuous markings made by the bottom.

Individual fish can, at times, be distinguished by a characteristic arch that separates them from their stationary surroundings. The reason for this is shown below. The distance to a fish when it moves into the sonar's cone of sound is shown as "A" Figure 32. When the fish has moved into the center of the cone, the distance to it will be shorter, "B", and as it moves out of the cone, the distance will increase again as shown in "C".

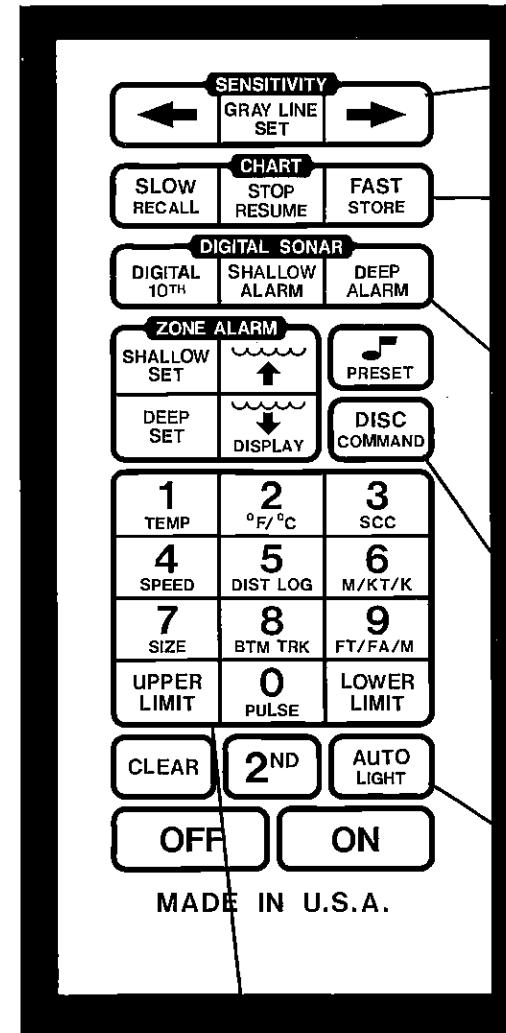
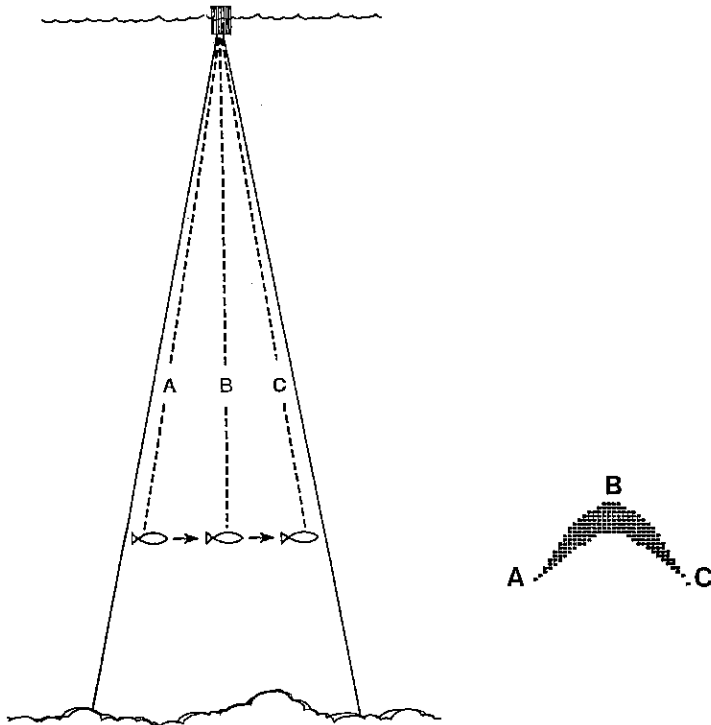

Figure 5

### UPPER LIMIT LOWER LIMIT

The upper and lower limit keys provide the way to select different depth ranges by pressing the desired depth and then pressing the appropriate upper or lower limit key. The upper limit key sets the depth for the top of the display, while the lower limit key determines the depth displayed at the bottom of the screen.

**GRAYLINE SET** Pressing this key allows you to adjust the grayline level using the sensitivity keys. There are 31 steps of GRAYLINE adjustment.

**CHART** The chart speed is controlled by the CHART group of keys. The X-50 has 10 chart speeds, ranging from very slow to fast. Pressing the FAST key speeds up the chart. The SLOW key decreases it. The chart speed can be stopped and started again using the STOP RESUME key.

**DIGITAL SONAR** The X-50 is really two sonars in one housing. The most obvious is the graph, designed to show all return echoes. The other sonar is the digital, designed for only one purpose: to show the bottom depth. These keys turn the digital display off or on and set the digital alarm functions.

**DISC** Discrimination is an adjustable noise rejection system. The levels of adjustment are 0 (off) through 10.

**AUTO** The AUTO key switches the X-50 in or out of the automatic mode. When the X-50 is first turned on, it automatically adjusts the sensitivity and range selection, and the word "AUTO" will be displayed in the upper left of the screen. By pressing the AUTO key, you can take control of the X-50, making manual adjustments as desired. When the X-50 is in the automatic mode, the word "AUTO" will be displayed under the sensitivity bar near the top of the display.

## OPERATION

When the X-50 is first turned on, it automatically finds and displays the bottom depth, sets the sensitivity level, and much more. If desired, the X-50 can be left in this automatic mode to find fish and the bottom conditions they prefer. However, virtually every function of the X-50 can be manually adjusted so that "fine tuning" of the unit to the surrounding conditions can be made. Take this manual out on the water as a reference guide to help you get the most out of your X-50.

A rectangular button with rounded corners and a black border, containing the word "ON" in white capital letters.

### ON

The ON key is located in the lower right corner of the keyboard. It is placed in this location so that it can be easily found—even at night. To turn the X-50 on, press the ON key. An audible beep will be heard signifying the X-50 knows that a key has been pressed. The chart lights will begin flashing, then stop after six seconds. The chart will begin scrolling across the display and the number "0" will flash. This number is the digital bottom depth display. After the unit has found the bottom, the depth will be displayed.

A rectangular button with rounded corners and a black border, containing the word "OFF" in white capital letters.

### OFF

To turn the X-50 off, simply press the OFF key.

A rectangular button with rounded corners and a black border, containing the text "2ND" in white capital letters.

### 2nd

The X-50 has many different functions, but only a limited amount of space for keys. Therefore, some of the keys have more than one function. Each key's primary function is printed in one color, while its second function is printed in white. The "2nd" key must be pushed to access the second function printed in white on the appropriate key.

For example, the AUTO key is also labeled "LIGHT". If you press the AUTO key by itself, the X-50 will be taken out of the automatic mode. However, if you press the 2nd key, then the AUTO key, the X-50's lights will be turned on. The 2nd key just reassigned the meaning of the AUTO key from AUTO to LIGHT.

Generally, wide cone angle transducers (20 degrees) are ideally suited for operating in shallow to medium water depths. The 20 degree cone angle allows you to see more of the underwater world. In 15 feet of water the 20 degree cone covers an area about six feet across. The 8 degree transducer covers only about a two foot circle.

The 20 degree transducer is almost always the best to use in fresh water, while the 8 degree transducer is used mostly in salt water. In a deep water environment, (300 feet—fresh water, 100 feet—salt water) the narrow cone angle is more desirable because it can penetrate to much deeper depths since the sound energy is concentrated in a smaller area.

Both 8 degree and 20 degree transducers give accurate bottom readings, even though the bottom signal is much wider on the 20 degree model because you are seeing more of the bottom. Remember, the shallow edge of the signal shows the true depth. The rest of the signal tells you whether you are over rocks, mud, etc.

Transducers on salt water boats need to be painted with a thin coat of anti-foulant paint to prevent organisms from growing. If unchecked, barnacles and other marine growth will cause a decrease in the transducer's sensitivity. Do not use a metal based anti-foulant paint as it will decrease the transducer's sensitivity. There are special anti-foulant paints specifically designed for transducers. They're readily available at most marine dealers.

## SIGNAL INTERPRETATION

Because your X-50 is both extremely sensitive and powerful, it can give you an accurate picture of the kind of bottom over which your boat is passing. A bottom of firm sand, gravel, shell, or hard clay returns a fairly wide signal. If the automatic sensitivity is turned off and the signal narrows down, it means that you have moved over a mud bottom because mud absorbs the sound wave and returns a weak signal. Turn up the sensitivity. GRAYLINE is especially effective in determining the composition of the bottom. With a hard bottom signal, the grayline will be wide. As the boat passes over the mud bottom, the grayline will narrow down, or it may disappear altogether. GRAYLINE works independently of the automatic function, so it can be used even if automatic sensitivity is on.

Big rocks or stumps on a smooth bottom send back signals above the bottom level signal. The height of the signal depends on the target's height. As you approach a post or a tree stump, it will be clearly visible as a short line extending above the bottom signal.

A steep slope returns a wide signal, the steeper the slope, the wider the signal, with the signal returned from a high underwater cliff being the widest of all.

Brush usually lies on the bottom and shows up as clumps rising above the bottom signal. Brush signals look similar to large rocks, however their signal is not as strong as rock.

## 18 = TOTAL SYSTEM RESET

The X-50 has an internal battery that keeps power supplied to the memory circuits even when the power cable is removed from the unit. To reset the X-50's functions to their factory settings, use the TOTAL SYSTEM RESET function. The X-50 will restart as if power had been turned off and back on again.

## TRANSDUCERS AND CONE ANGLES

The sound waves from the transducer spread out into the water in a cone shaped beam, much like the beam from a flashlight. The angle between the outside edges of the cone is called the cone angle.

Lowrance offers a choice of transducers with either an 8 or 20 degree cone angle that will interchange with any of the 192 kHz sonar products. In other words, any Lowrance sonar instrument can be used with any Lowrance transducer of the same frequency with no loss of performance. However, the use of any other manufacturers' transducer will result in a loss of performance.

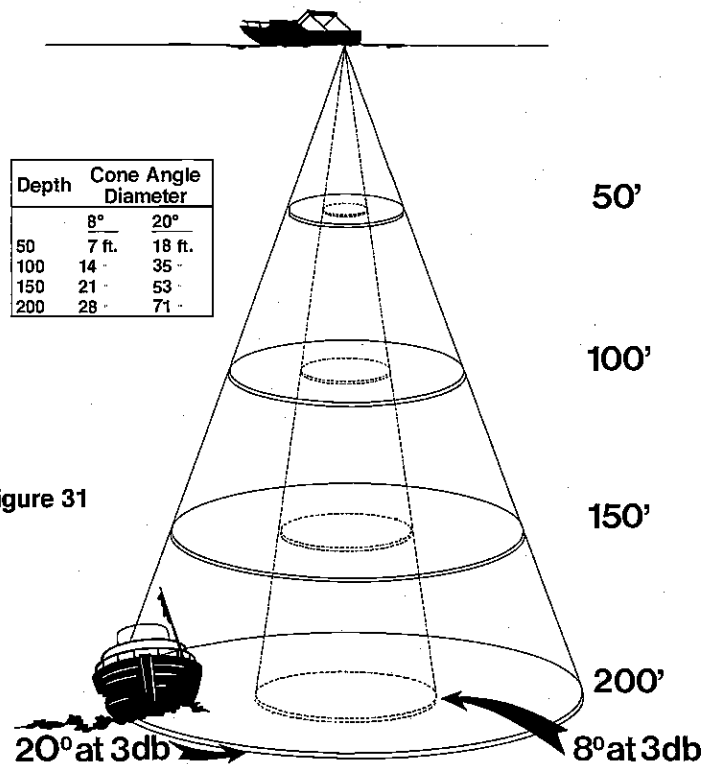

CLEAR

## CLEAR

If an incorrect key is pressed, wait six seconds and it will automatically be erased or "cleared." The X-50 provides a faster method of erasing mistakes, however. Instead of waiting six seconds, simply press the CLEAR key and the last entry will be erased.

For example, if you wish to turn on the lights, the proper keys to press are 2nd, AUTO. However, if the 0 key was accidentally pressed instead of the 2nd key, you can press the CLEAR key which erases the 0 and allows you to start over.

The CLEAR key also erases or sets to zero other functions of the X-50 including SCC and Discrimination. As the other functions are described in this manual, the CLEAR key's operation will be explained in detail.

AUTO  
LIGHT

## AUTO

When the X-50 is first turned on, the automatic mode is on. To switch it into the manual mode, press the AUTO key which is located above the ON key. The word AUTO at the top of the display will be erased, auto sensitivity and auto ranging will both be cancelled and you will have complete manual control of the X-50. The X-50 can be returned to the automatic mode at any time by simply pressing the AUTO key again.

SENSITIVITY  
GRAY LINE  
SET

## SENSITIVITY

When first turned on, the X-50 is in the auto search mode. This means the sensitivity and range are automatically adjusted by the micro-computer to find and lock onto the bottom. The sensitivity can be manually adjusted if desired while in either the automatic or manual mode to suit conditions.

The sensitivity level is displayed by a horizontal bar at the top of the display. When the sensitivity is at minimum, the bar is very short. As sensitivity is increased, the bar will travel to the right, increasing in length correspondingly. When the sensitivity is set to maximum, the bar will extend across the top of the display. There are 31 steps of sensitivity adjustment.

### Automatic Sensitivity

When the X-50 is in the automatic mode, the sensitivity of the receiver will be adjusted above the minimum required to pick up the bottom signal. This enables the X-50 to display fish, structure, and other small targets while in the automatic mode.

The sensitivity level can be changed while the X-50 is in the automatic mode. This may be desirable if the level of sensitivity chosen by the X-50 is not enough to show fish or other small detail. If desired, any amount of sensitivity up to the maximum may be added or any amount of sensitivity down to the minimum may be subtracted from the current setting.

To adjust the sensitivity while the X-50 is in the automatic mode, simply press either the right arrow key > to increase the sensitivity or the left arrow key < to decrease it. Holding the keys down will increase or decrease the sensitivity faster. If the value goes below the minimum, the X-50's audible tone will "flutter". The same is true if you try to go above the maximum level. As you press the arrow key, the sensitivity bar will move right or left, according to the amount of sensitivity chosen. The X-50 will still automatically adjust the sensitivity as conditions change, but it will always keep the amount that you added or subtracted.

### Sensitivity—Manual Operation

At times, it may be desirable to turn the automatic functions off and "fine tune" the X-50 to the current conditions.

To manually adjust the sensitivity, press the AUTO key once, and auto sensitivity will be turned off. The word AUTO at the top of the display will disappear, signifying that the X-50 is in the manual mode. The sensitivity can now be adjusted to the desired level.

Figure 6 demonstrates a graph with too little sensitivity, while on the right, the sensitivity is adjusted properly; a fish is now visible, the surface clutter is more pronounced, and the bottom signal has widened.

When the horizontal bar reaches the far right hand side of the screen, the sensitivity level is at maximum. If high sensitivity settings are used, a second bottom echo may appear. This is normal and is caused by the returning signal reflecting off the surface of the water, making a second trip to the bottom and back again. This is called "second echo".

Occasionally, when high sensitivity levels are used, the display will turn black. This happens when there are large amounts of surface clutter, thermoclines, turbulent water, or suspended particles such as silt that reflect the sonar signal. This does not damage the unit; to correct it, simply turn down the sensitivity level.

To return to the Automatic mode, press the AUTO key. Remember, both automatic sensitivity control and auto ranging functions are turned off and on by pressing the AUTO key.

### 17 = KEEL OFFSET

Most sailboats have a keel or a centerboard that extends many feet below the surface. Many power boats with displacement hulls also extend many feet below the surface of the water. The digital sonar calculates the bottom depth from the transducer's face. If the boat hull sticks below the transducer, then it can run aground when the digital says there is still clearance. The X-50 provides a keel offset adjustment that allows for the depth correction between the face of the transducer and the bottom of the hull. For example, if the bottom of the hull is 4 feet deeper than the transducer location, then the keel offset on the X-50 can be adjusted by pressing 17 from the menu selection. A new menu will appear:

KEEL  
OFFSET IS  
0.0 FT

ENTER  
VALUE  
IN TENTHS  
THEN PRESS

OR

UPPER  
LIMIT FOR  
NEGATIVE  
OFFSET

LOWER  
LIMIT FOR  
POSITIVE  
OFFSET

Since the hull in our example boat is 4 feet lower than the transducer, we want to use a negative offset. So, while the above menu is still on the screen, press 40. This is actually 4.0 feet. (If you just press 4, the offset will be .4 or four tenths of a foot.) The X-50 will now display the depth with a four foot offset. In other words, if the bottom is fifty feet from the transducer face, with a four foot negative offset the X-50 will display the bottom depth as 46 feet.

A new menu will appear:

SPEED  
CORRECTION  
0%

ENTER  
VALUE  
IN PERCENT  
THEN PRESS

UPPER  
LIMIT FOR  
NEGATIVE  
CORRECTION

OR

LOWER  
LIMIT FOR  
POSITIVE  
CORRECTION

Run the boat at a steady speed through a measured mile. At the end of the mile, check the stopwatch to see how long it took. From that you can calculate the speed that the boat travelled. If the speedometer is correct, then no correction needs to be made. If the speedometer reading is off, then enter the percentage that it is off. For example, if the speedometer reads 5 percent fast, once you get the above menu, press 5, UPPER LIMIT. That will give the speedometer a 5% negative correction which should cause it to display the correct boat speed.

**15 = TEST PATTERN ON**  
**16 = TEST PATTERN OFF**

A test pattern is stored in the X-50's memory that can be recalled at any time. It is simply numbers 0 through 9 and the letters of the alphabet. To display the test pattern, once the menu appears, press 15. To turn the test pattern off, get the menu, then press 16.

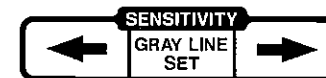
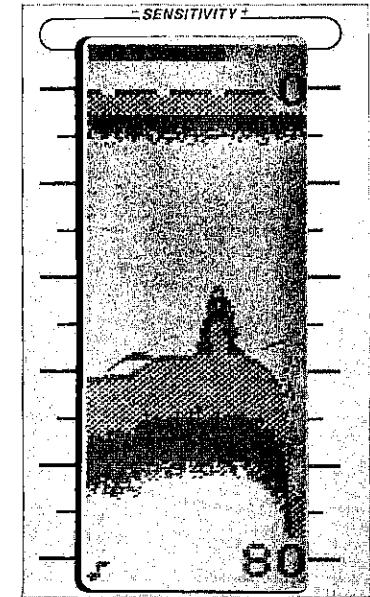
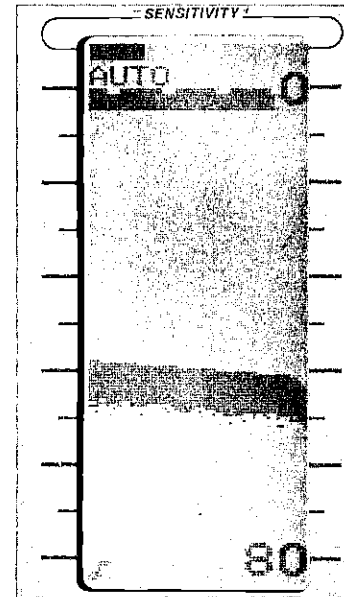

## GRAYLINE

The GRAYLINE function can be used to outline bottom contour which might otherwise be hidden beneath trees or brush. It will also give clues to the composition of the bottom, i.e. determine if the bottom is hard or soft. A hard bottom returns a very strong signal causing a wide gray line. A soft, muddy or weedy bottom returns a weaker signal which is emphasized with a narrow gray line.

When the X-50 is first turned on, the GRAYLINE level is preset. To adjust it, press the GRAYLINE SET key. The word "AUTO" in the upper left corner of the screen will change to the word "GRAY". The sensitivity bar now reads the level of GRAYLINE in use. To adjust the GRAYLINE level higher, press the right arrow key in the SENSITIVITY section on the keyboard. To decrease the GRAYLINE level, press the left arrow key in the SENSITIVITY section on the keyboard. After making the adjustments, the word "GRAY" will disappear after six seconds and the arrow keys will revert to sensitivity adjustment again.

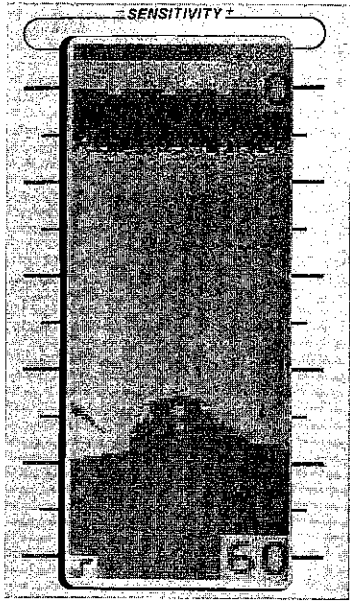

Figure 8 GRAYLINE "OFF"

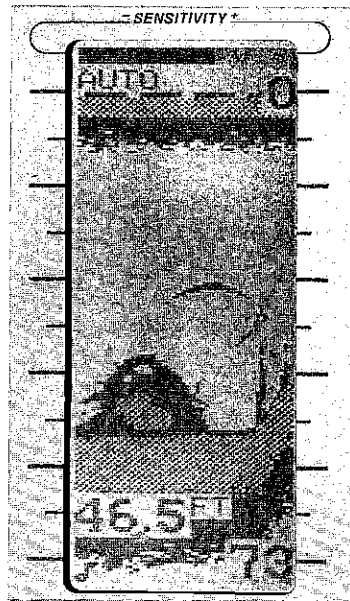

Figure 9 PROPER SETTING



### CHART SPEED

When the X-50 is turned on for the first time, the chart scrolls at a pre-determined speed. If a higher speed is desired, press and hold the FAST key in the CHART section of the keyboard until it runs at the desired speed. To slow the display, press and hold the SLOW key. Whenever either of these keys are pressed, the sensitivity bar at the top of the display will change to a dashed line and the word "CHT" will replace the word "AUTO" near the top of the display. The dashed bar represents the chart speed. If you press and hold the FAST key for example, the bar will start moving to the right, signifying that the chart speed is increasing. There are 10 steps of chart speed. When the horizontal bar reaches the far right side of the screen, the chart speed is at its maximum value. The X-50 will "flutter" signifying the maximum chart speed has been reached.

If the automatic mode or digital function is on, the maximum chart speed cannot be attained. (The chart bar will stop two steps from the far right and the audible tone will "flutter".) Turning both the digital and the automatic mode off will allow the maximum chart speed to be attained. (Ten steps of chart speed are available if the digital and AUTO are off, Eight steps of charts speed available with digital and AUTO on.)

- 8 = ENABLE DIGITAL AVERAGING
- 9 = DISABLE DIGITAL AVERAGING

The digital sonar in the X-50 is a highly sensitive sonar that gives extremely rapid updates of the water depth. Under most conditions, the bottom contour changes so rapidly that the depth display can appear to "jitter". In other words, the display will change the depth so quickly that it can be difficult to determine the actual bottom depth. To alleviate this situation, the X-50 can average the bottom readings and place the result on the display. When the X-50 is first turned on, averaging is enabled. To disable averaging, press the 9 key once the menu appears. To enable averaging once again, press the 8 key.

- 10 = BATTERY BACKUP ENABLED
- 11 = BATTERY BACKUP DISABLED

The X-50 has battery backed up memory which allows it to retain all settings even if the power cable is removed from the unit. The battery can be turned off or back on at anytime. When the X-50 is shipped from the factory, the battery is turned on. To turn it off, press 11. To turn it on again, press 10.

- 12 = SCALE ON
- 13 = SCALE OFF

The upper and lower limit numbers on the right side of the display can be turned on or off as desired. When the X-50 is shipped from the factory, the scales are turned on. To turn them off, press 13 after the menu appears. To turn them back on again, press 12.

- 14 = CALIBRATE SPEED

Due to variations in boat hulls and sensor mounting locations, the speedometer on the X-50 may need to be calibrated. The X-50 allows corrections to be entered using the CALIBRATE SPEED command. To use it, press 2nd, DISC (COMMAND) until the CALIBRATE SPEED function on the menu appears. Then press 14.

## 2 = GRAYLINE CHECKERBOARD

## 3 = GRAYLINE LINES

GRAYLINE can be displayed on the X-50 with a checkerboard pattern or with lines and spaces. When the X-50 is shipped from the factory, the checkerboard pattern is enabled. To change to lines, press the 3 key. To switch back, press the 2 key.

## 4 = SPEAKER VOLUME

The volume of the speaker can be changed by pressing the 4 key. A message will be displayed on the screen: USE SENS. KEYS TO ADJUST VOLUME (the sensitivity keys are used to adjust the volume of the speaker) and the speaker will begin beeping. Pressing the right arrow key will increase the volume, the left arrow key decreases it. The sensitivity bar will move to the right or left, signifying the volume level. The speaker will stop beeping six seconds after the last key has been pressed.

## 5 = CLEAR DIST LOG

The distance log will start operating from the time the X-50 is first turned on. To reset the distance log to zero, press the 5 key while the menu is on the screen.

## 6 = NARROW AUTO RANGE WINDOW

## 7 = WIDE AUTO RANGE WINDOW

The limits that the X-50 will autorange can be changed if desired. When the X-50 is first turned on, the narrow autorange is enabled. This means that if the bottom signal goes below the 90% point on the screen, the X-50 will autorange and place the bottom signal at the 50% point on the screen. If the bottom signal goes above the 40% position, the X-50 will autorange and place it at the 80% position on the display. This keeps the bottom signal in the lower half of the display, allowing you to see fish and other targets.

The wide autorange will move the bottom signal to the 25% point if it goes below the 90% point. If the bottom signal goes above the 15% point, then the X-50 will autorange it back to the 80% point. This allows the bottom signal to travel almost the entire vertical area of the display. The only disadvantage to this is that echoes above the bottom signal cannot be seen when the bottom signal is near the top of the screen. However, if you wish to only track the bottom signal, while keeping the automatic range changes to a minimum, then the wide autorange window will be useful.

To change to the wide autorange, press the 7 key while the menu is on the screen. To change back to narrow autorange, press the 6 key.

To view the chart speed without changing it, press 2nd, STOP/RESUME. The sensitivity bar will disappear and the chart speed bar will replace it for a six seconds.

At times it is desirable to stop or "freeze" the display to examine an echo before it scrolls off the screen. Pressing the STOP/RESUME key once will freeze the display. In the upper left corner of the display, the word "AUTO" will change to "STOP" to signify that the X-50 is in the "freeze" mode. Pressing STOP/RESUME again will start the display moving at the last chart speed setting. If the digital sonar is on, the bottom depth will continue to be displayed on the screen. The digital does not stop when the chart is in the "freeze" mode.

## SCALE MARKERS

There are ten scale markers printed on both sides of the X-50's display to help you determine what the depth of a target is. For example, if the range is 0-60 feet, and a target (such as a fish) was displayed next to the fifth line, then it is 30 feet deep. (60 feet divided by 10 lines = 6 feet per line. 5 lines times 6 feet per line = 30 feet.) This method works no matter what the upper and lower limits are, but to make it easier use upper and lower limits in multiples of ten, i.e. 10, 20, 30, etc.

SCALE MARKERS

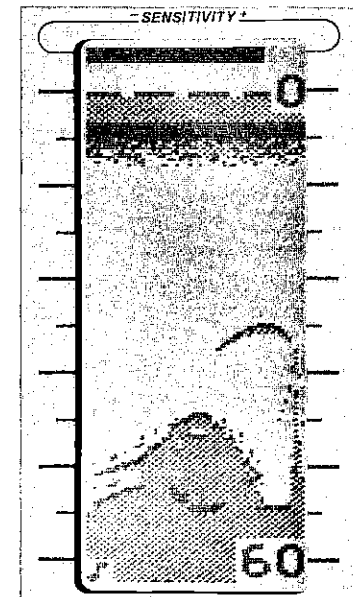

SCALE MARKERS

Figure 10

To use the scale markers with a zoom, simply subtract the upper limit from the lower limit, then divide that number by ten to get the number of feet per line. For example, if a target is on the third line and the upper limit is 120 feet with a lower limit of 160 feet, then subtract 120 from 160 which equals 40. To get the number of feet per mark, divide 40 feet by 10 lines which equals 4. Now multiply 4 times 3 (target is at the third line) and you get 12. Add 120 (upper limit) to 12 and the depth of the target is 132 feet deep.

## RANGE

When the X-50 is in the automatic mode, the ranges will automatically change to keep the bottom signal on the display as the bottom depth changes. At times, however, it may be desirable to expand the range or zoom in on a target. The upper limit can be set from 0 to 6490 feet and the lower limit can be set from 10 to 6500 feet. Any combination of the two limits may be used, provided that the lower limit is no closer than ten feet to the upper limit. If a segment less than ten feet is entered, the X-50 will "flutter" and the range will remain at the previous setting.

(Note: Maximum depth capability will depend upon the water and bottom conditions, type of transducer, and quality of transducer installation.)

LOWER  
LIMIT

## LOWER LIMIT

### Automatic Operation

When the X-50 is first turned on, it will automatically find and display the bottom signal, picking a lower limit that will put the bottom signal in the lower portion of the display. As the bottom depth changes, the X-50 will automatically change the lower limit to keep the bottom signal on the display. When the X-50 changes ranges while in the automatic mode, the lower limit selected will always be a multiple of ten. In other words the lower limit will be a number that ends in zero such as ten, twenty, forty, one hundred, etc.

The lower limit may be changed while the X-50 is in the automatic mode, however the lower limit cannot be set shallower than the bottom. If a lower limit is chosen that is less than the bottom depth, the X-50 will ignore the command.

To change the lower limit while the X-50 is in the automatic mode, simply press the desired depth, then the LOWER LIMIT key. For example, changing the lower limit to 50 feet requires the following keys to be pressed: 5, 0, LOWER LIMIT.

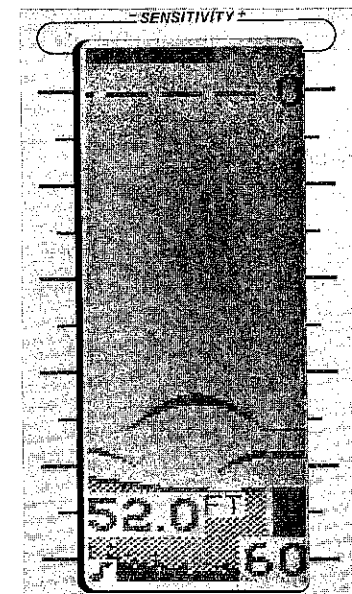
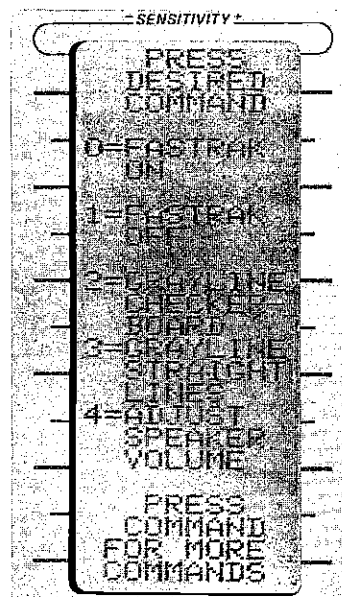

0 = FASTRAK ON  
1 = FASTRAK OFF

FASTRAK is a feature that converts all echoes to short horizontal bars on the far right side of the display. The graph display continues to operate normally, however. In essence, FASTRAK is a vertical bar display that enables you to determine a target's depth easier. For example, see figure 30 above. With FASTRAK enabled, the fish echo is making a mark close to the 8th line on the scale. With an upper limit of 0 and a lower limit of 60, then each scale mark is 6 feet which places the fish at approximately 54 feet. Since FASTRAK is so close to the scale markers, it makes it a little easier to line up the target's depth with the scale.

To turn FASTRAK on, press the 0 key.

To turn FASTRAK off, press the 1 key.

## COMMAND

The X-50 has many more features than available keys. The COMMAND key lets you access "menus" of other functions. A typical menu looks like figure 29.

To find the desired function, press 2nd, DISC (COMMAND). The first menu will appear for six seconds as shown in figure 29. If you don't see the desired function, press the DISC (COMMAND) key again. Continue pressing it until the desired function is shown on the display. All of the functions will be numbered. To activate the desired function, simply press the number on the keyboard that corresponds to the function.

A faster way to execute menu functions is to press the function's number first, then press 2nd, DISC (COMMAND). For example, the CLEAR DISTANCE LOG function is number 5. To clear the log one must either press 2nd, DISC (COMMAND), then press DISC (COMMAND) until the CLEAR DISTANCE LOG function is displayed and press the number 5 on the keyboard, or simply press 5, 2nd, DISC (COMMAND). Both methods can be used on all menu functions.

Each of the functions are listed below in order of appearance on the menus. Remember, 2nd, DISC (COMMAND) must be pressed to enable or disable any of the following functions.

- 0 FASTRAK ON
- 1 FASTRAK OFF
- 2 GRAYLINE CHECKERBOARD
- 3 GRAYLINE LINES
- 4 SPEAKER VOLUME
- 5 CLEAR DISTANCE LOG
- 6 NARROW AUTO RANGE WINDOW
- 7 WIDE AUTO RANGE WINDOW
- 8 ENABLE DIGITAL AVERAGING
- 9 DISABLE DIGITAL AVERAGING
- 10 BATTERY BACKUP ENABLED
- 11 BATTERY BACKUP DISABLED
- 12 SCALE ON
- 13 SCALE OFF
- 14 CALIBRATE SPEED
- 15 TEST PATTERN ON
- 16 TEST PATTERN OFF
- 17 KEEL OFFSET
- 18 TOTAL SYSTEM RESET

## Manual Operation

The lower limit may be changed to any setting while the X-50 is in the manual mode, regardless of where the bottom signal is.

To change the lower limit in manual mode, first make certain the word "AUTO" is not displayed at the top of the screen, signifying that the automatic mode is off. (Note: This also disables the automatic sensitivity function.) If the automatic mode is on, press the AUTO key once to disable it. Next, enter the lower limit desired from 10 to 6500 feet and press the LOWER LIMIT key. The display will immediately change to the new depth range and display the new lower limit at the bottom of the screen.

For example, to set the lower limit to 31 feet, press 3, 1, LOWER LIMIT.

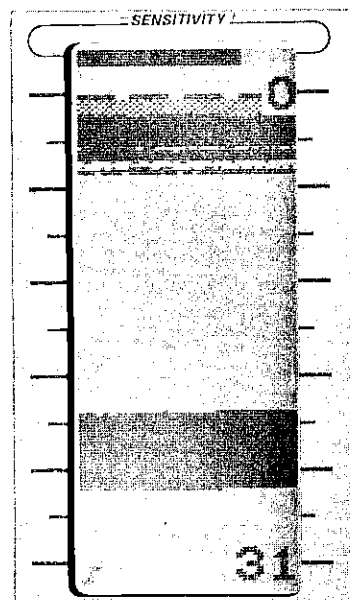

UPPER  
LIMIT

## UPPER LIMIT

Often it's desirable to expand or "ZOOM" a section of the display to show more detail. You can do this on the X-50 by using the Upper Limit feature. When the X-50 is in automatic, the upper limit is automatically set to zero and cannot be changed while in the automatic mode. (Unless the Auto Range with Zoom Bottom Track feature is used. See page 16 for details.) However, if the X-50 is in the manual mode, any upper limit may be chosen provided it is no closer than ten feet to the lower limit.

To change the upper limit of the display, first make certain the X-50 is in the manual mode. Then simply press the desired depth (any number between 0 and 6490 feet) and then the UPPER LIMIT key. Remember, the only restriction on the upper limit is that it must not be closer to the lower limit than 10 feet. In other words, if the lower limit is set to 80 feet, the upper limit cannot be set any closer than 70 feet. A ten foot segment or larger is required.

Upper and lower limits may be set in various combinations to show segments from the surface to the bottom and anywhere in between. This permits a scale expansion or "zoom" of a portion of the display.

Example: Set the range from 16 to 31 feet

Press: 1, 6, UPPER LIMIT,  
3, 1, LOWER LIMIT

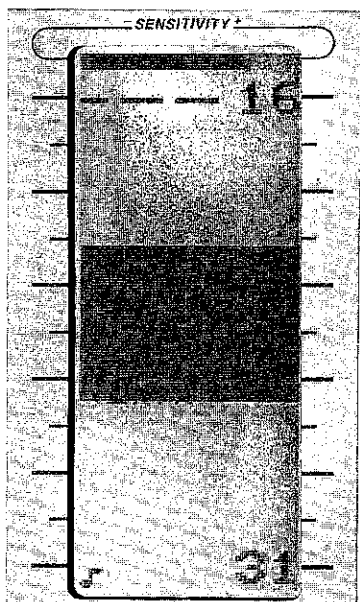

Figure 12



### AUTO RANGE WITH ZOOM BOTTOM TRACK

Although the upper limit cannot be directly changed while in the automatic mode, a "window" can be chosen that will track the bottom signal and show an enlarged or "zoomed" picture of the underwater world using the AUTO RANGE with ZOOM BOTTOM TRACK feature.

The digital bottom depth will revert to the medium number size, all alarms will be turned off, the speedometer, temperature display, and log will also be turned off. Automatic will be turned back on. The range will be changed if the bottom signal is not on the display.

The memory function can be turned off if desired. For more information, see the COMMAND function on page 30.



### DISPLAY MEMORY

The X-50 has two "pages" of display memory available, allowing you to store an entire screen when desired. Thanks to the internal battery, the display memory can be retained even if power is disconnected from the X-50. By pressing a few keys, the display that is currently on the screen will be stored into memory, complete with upper and lower limits, digital bottom depth, temperature, and speed. If any or all of these functions are displayed on the screen, then they will be stored and displayed when recalled.

There are two memory locations for display memory, numbered one and two. To store the current display into number one, press 1, 2nd, FAST (STORE). The current display is now stored in location one. To store a different display, press 2, 2nd, FAST (STORE). Now two different displays are stored into memory. If desired, new displays may be stored into the two locations by pressing 1, 2nd, FAST (STORE) or 2, 2nd, FAST (STORE), but the previous display will be erased each time a new display is stored.

To recall a display stored into memory, simply press the memory location number, either one or two, then the 2nd key, then the SLOW (RECALL) key. For example, to recall display one, press 1, 2nd, SLOW (RECALL). The display that was stored in memory location number one will immediately be displayed. It will remain on screen until any key is pressed. The CLEAR key is a good one to use for that.

**NOTE:** When storing or recalling a screen into memory location 1, the 1 does not have to be pressed. For example, press 2nd, FAST (STORE) instead of 1, 2nd, FAST (STORE) to store a screen into memory or 2nd, SLOW (RECALL) instead of 1, 2nd, SLOW (RECALL) to recall screen memory 1.

## PULSE

In sonar, there is a relationship between transmitter pulse length and resolution. Resolution, in this case, is the ability of a sonar to separate targets. The shorter the pulse length, the better the sonar's ability to separate targets. However, in deep water, the shorter the pulse length, the less likely a return echo will be received. In fact, the X-50 automatically increases the pulse length as the depth increases. In shallow water, a narrow pulse length is beneficial, since the probability of echo detection is high. For even better target separation, the X-50 gives you the capability of changing the pulse length to a more narrow length than would normally be used. Combine the narrow pulse length with a 10, 20, or even a 30 foot segment or "zoom" and the X-50 will display small detail far better than other Liquid Crystal Graphs.

To change to a narrow pulse, press 2nd, 0 (PULSE). A menu will appear (see figure 28). Simply press 2 for the narrow pulse length. If fishing in deeper water, press 2nd, 0 (PULSE) and then press 1 to switch back to normal pulse length.

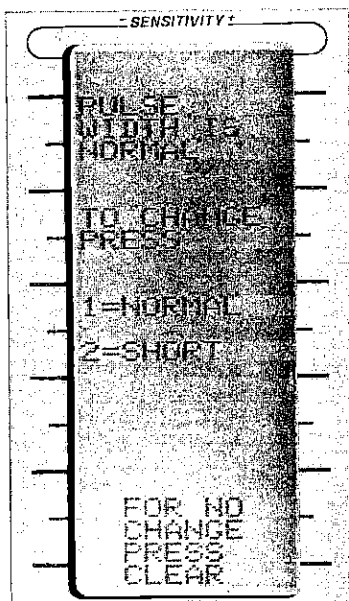

Figure 28



## PRESET

The X-50 has an internal battery that keeps power supplied to the memory circuits even when the power cable is unplugged from the unit. This allows the X-50 to retain all the settings that were in effect when it was last used. However, at times it may be desirable to erase these settings and start over. Using the PRESET function allows the X-50 to be reset to the factory standard settings. To reset the X-50, simply press 2nd, \*(PRESET).

To use this feature, a zoom window must be chosen. For example, use a 20 foot zoom window. This means that the X-50 will keep the upper limit setting 20 feet above the lower limit and place the bottom signal in this window, tracking it as it moves shallower or deeper. Press 2, 0, 2nd, 8. The X-50 will choose an upper and lower limit that will place the bottom signal in the 20 foot window. The bottom will be tracked and always kept inside this window. If the segment size is 40 feet or greater, the bottom will be tracked with window limits ending in zero (10, 20, 30, etc.), otherwise the limits will be in one foot increments.

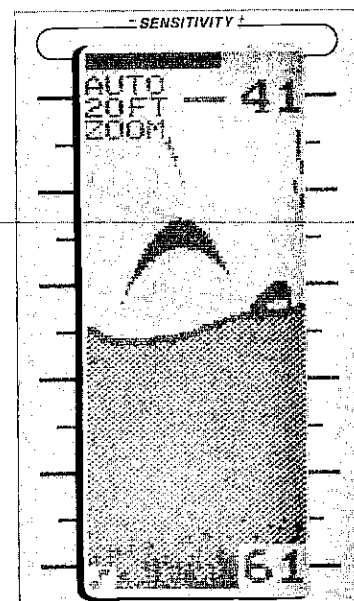

Figure 13

To exit from this function, press 2nd, 8 (BRM TRK) or press the AUTO key to turn off the automatic mode.



## DIGITAL

A complete digital sonar is built inside the X-50. It automatically discriminates between the valid bottom echoes and false echoes from fish, thermoclines, or other signals. The digital display will show only the bottom depth. It can be used any time, regardless of the mode the X-50 is in.

Remember, if the chart is in the freeze mode, the digital display will continue to show the bottom depth as it changes. It does not freeze when the chart does.

When the X-50 is first turned on, the digital will flash "0" until it has "locked on" to the bottom signal. Once it has acquired the bottom depth, it will display the depth in the lower left of the display.

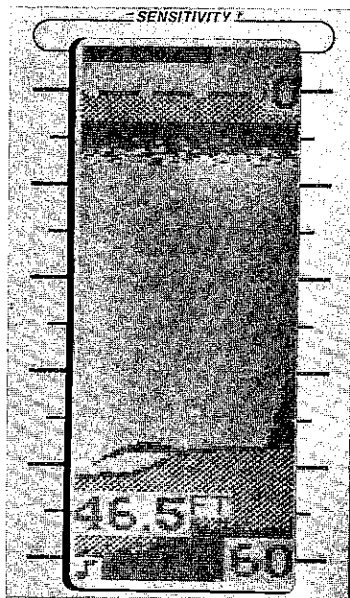

Figure 14

DIGITAL BOTTOM DEPTH

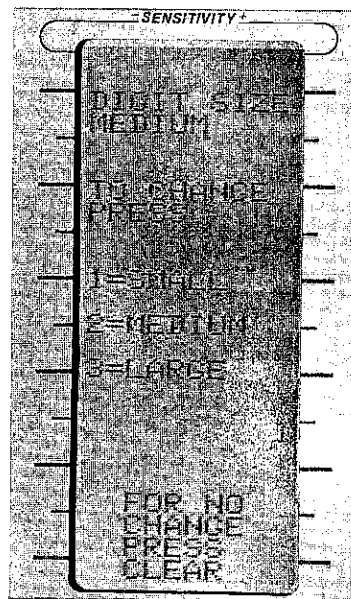

Figure 15

There are three different sizes of the digital numbers for the display, small, medium, and large. When first turned on, the digital number size is medium. To change to a different size, press 2nd, 7. A menu will appear (see figure 15) and you will be prompted to press the 1 key for small digital numbers, 2 for medium, or 3 for large digital numbers. After pressing the desired number on the keyboard, the menu will disappear. If number three, "large digital" is selected, the chart will not be displayed (see Figure 16). Instead, the screen will be cleared, the bottom depth will be displayed in large digits, speed and temperature will also be displayed (if turned on), and the depth alarm settings will be displayed at the bottom of the screen. This turns the X-50 into a digital sonar only and allows it to better track the bottom signal. One reason to use the digital in this manner would be if you are going to travel at high speed from one part of a lake to another and you just want to know the bottom depth. This will give both the fastest possible depth updates plus an easy-to-read display.

To change back into "normal" mode, simply press 2nd, 7 again and choose either 1, small numbers or 2, medium numbers.

The digital display can be turned off by pressing the DIGITAL key in the DIGITAL SONAR portion of the keyboard.

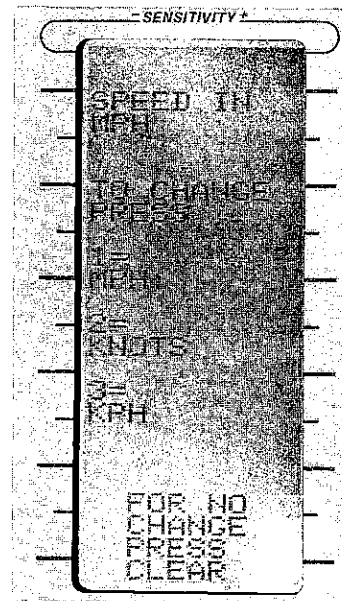

Figure 26

BOAT SPEED

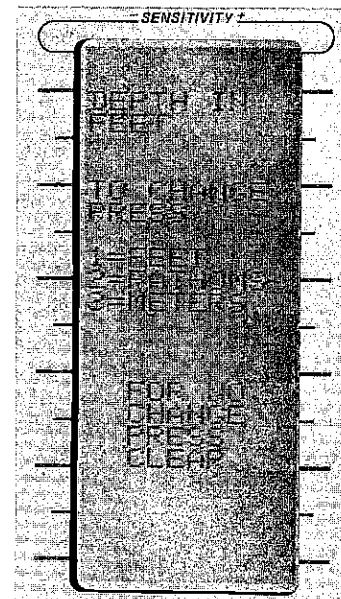

Figure 27

## LOG

**5**  
DIST LOG

If the optional speed sensor, model LSS-5 is attached to the X-50, then total distance travelled or log can be displayed on the X-50's screen. To display the log, press 2nd, 5. The distance travelled since the X-50 was last turned on will be displayed in statute miles. To reset the log, see the COMMAND function key instructions on page 30. To turn the log display off, press 2nd, 5 again.

**9**  
FT/FA/M

## FEET-FATHOMS-METERS

The X-50 can display the depth in either feet, fathoms, or meters. When it is first turned on, the display reads in feet. To change it to fathoms or meters, press 2nd, 9 (FT/FA/M). A menu will be displayed on the screen (see figure 27) indicating that the depth is in feet. To change to fathoms, press the 2 key on the keyboard, or press 3 to change to meters. For no change press the CLEAR key. After the selection is made, the unit will resume operation.

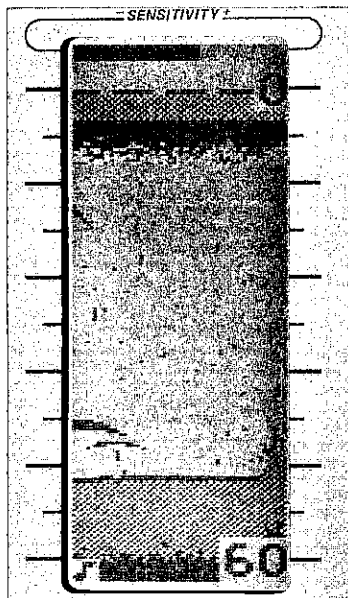

SCC OFF

Figure 24

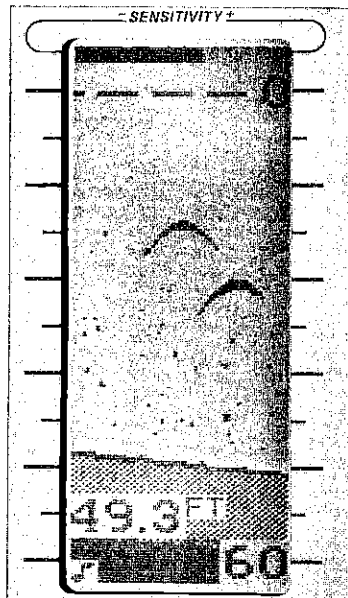

SCC ADJUSTED PROPERLY

Figure 25

To view the SCC level, simply press 2nd, 3 (SCC).  
To turn SCC off, press 0, 2nd, 3 (SCC).

## SPEED

If the optional speed transducer, model LSS-5 is installed, then the X-50 is capable of displaying boat speed and distance travelled or log. To display the boat speed, press 2nd, 4 (SPEED). The current boat speed in statute miles per hour will be displayed immediately above the digital bottom depth. To change to knots or kilometers, press 2nd, 6(M/KT/K). A menu will appear (see figure 26) asking you to press 1 for statute miles per hour, 2 for knots, 3 for kilometers per hour.

To turn the speed display off, press 2nd, 4 (SPEED) again.

DIGITAL  
BOTTOM DEPTH

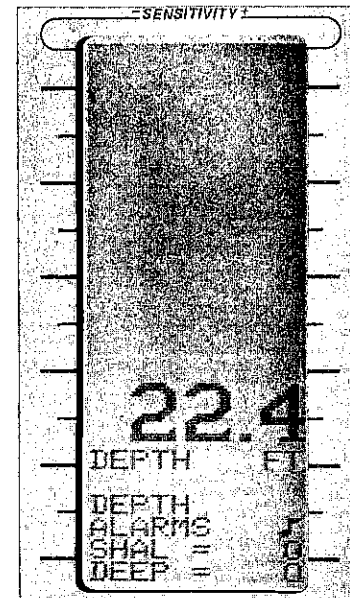

Figure 16

## 10th

The digital sonar will display the bottom depth in tenths of a foot. If the bottom goes deeper than 99.9 feet, tenths will automatically be disabled and the bottom depth will be displayed in whole numbers. Tenths will not come back on automatically if the depth goes deeper than 99.9 feet and comes back above 100 feet. If desired, tenths can then be turned on by pressing 2nd, DIGITAL (tenths) in the DIGITAL section of the keyboard.

To turn tenths off, press 2nd, DIGITAL.

## ALARMS

The X-50 has two different alarms, a zone alarm and a depth alarm. The zone alarm has an indicator bar on the left side of the screen. The alarm then "chirps" and the words "ZONE ALM" will flash on the display whenever any echo such as a fish, school of fish, or the bottom echo is detected inside the boundaries of the zone alarm bar.

The depth alarm has upper and lower limits, but they do not have to be used together. Only the bottom signal will trigger the depth alarm. Fish, noise, or any other targets will not set it off. The depth alarm sounds with a fast beep whenever the bottom echo is detected shallower than the alarm upper limit, and a slow beep when the bottom is deeper than the alarm's lower limit. The words "DEPTH ALM" flashes on the display whenever the depth alarm is triggered.

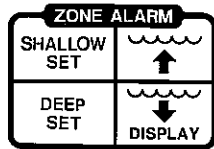

## ZONE ALARM

The Zone Alarm can also be thought of as a fish alarm. It will sound when an echo is detected inside its window.

To set the Zone Alarm, press the SHALLOW SET key in the ZONE ALARM section of the keyboard. The words "ZONE ALM" will be displayed in the lower left corner of the screen. A vertical bar will be displayed on the left side of the screen. This is the Zone Alarm's "window". Any echo that appears between the top and bottom of this bar will sound the alarm. Both the shallow and deep ends of this bar can be adjusted to make a smaller or larger alarm "window".

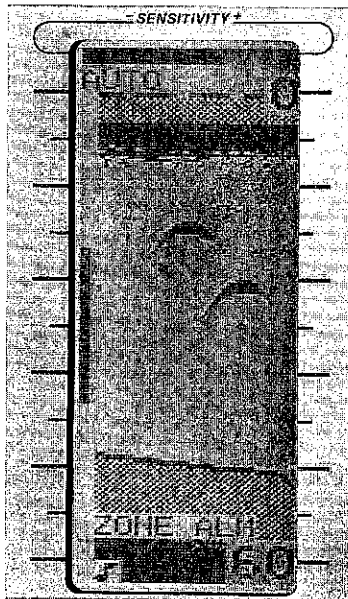

ZONE ALARM BAR

Figure 17

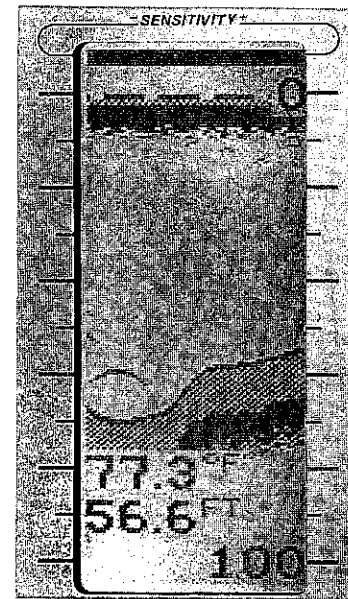

Figure 22

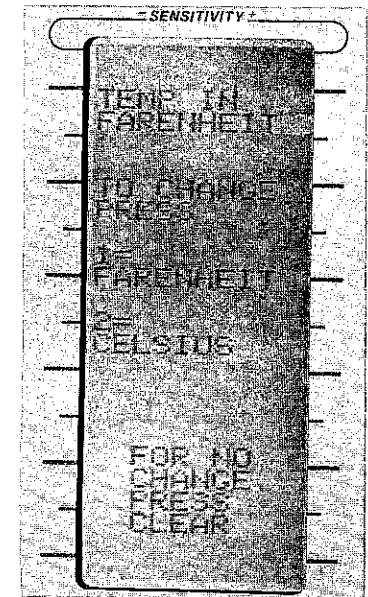
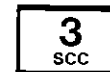

Figure 23



## SURFACE CLARITY CONTROL

The markings at the top of the display can at times extend many feet below the surface. This can interfere with fish signals or other targets. These markings are called Surface Clutter and are caused by wave action, boat wakes, bait fish, temperature inversions, and other causes.

The surface clutter can be reduced or eliminated by using the Surface Clarity Control or SCC. SCC varies the gain of the receiver between each transmit pulse, while the receiver is "listening" for the return echoes. The gain is the lowest for echoes near the surface. It is gradually increased as the depth increases. The maximum depth that SCC will affect is three-quarters of the selected depth range. For example, on a 0 to 60 foot range, SCC would have an effect from the surface to 45 feet.

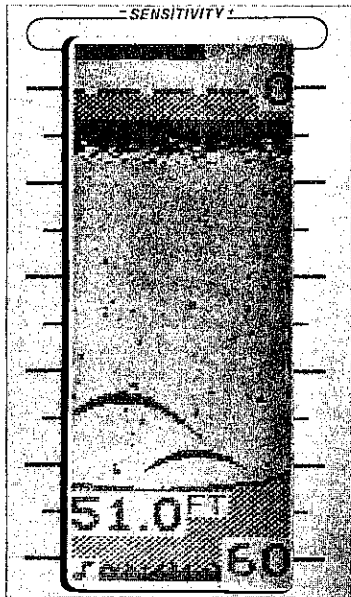

DISCRIMINATION OFF

Figure 20

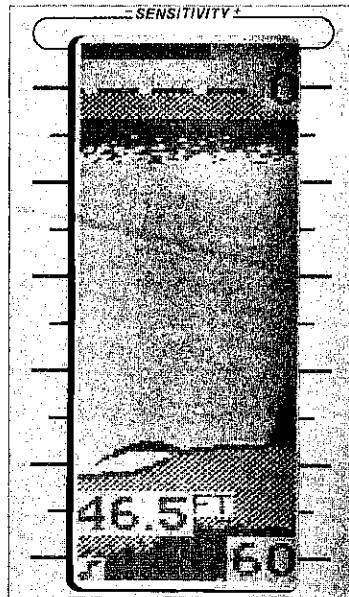

DISCRIMINATION ADJUSTED PROPERLY

Figure 21

Discrimination may be turned off by pressing 0, DISC or CLEAR, DISC. To view the Discrimination setting without changing it, press the DISC key.

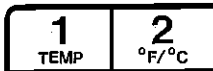

## TEMPERATURE

To display the surface water temperature, press 2nd, 1 (TEMP). The temperature will be displayed immediately above the digital bottom depth in degrees Fahrenheit. See Figure 22. To turn the temperature display off, press 2nd, 1 (TEMP) again.

The temperature display can be changed from degrees Fahrenheit to degrees Celsius. To change, press 2nd, 2 (F/C). A menu (see figure 23) will appear showing the current temperature mode. To change modes, press 1 for degrees Fahrenheit, 2 for degrees Celsius, or CLEAR for no change. The menu will disappear after six seconds if no keys are pressed, leaving the temperature display in the current mode.

To adjust the shallow (top) alarm, press the SHALLOW SET key, then press the up arrow key to move the top of the alarm window up, or the down arrow key to move the top of the zone deeper. The longer you hold the arrow key, the faster the end of the zone alarm bar will travel. The bottom of the zone can be set in the same manner using the DEEP SET key. Press the DEEP SET key, then press either the up arrow key to make the bottom part of the window move shallower, or press the down arrow key to move the bottom of the window deeper. After the keys are released, the bar will remain on the screen for six seconds, and then disappear.

As long as the "ZONE ALARM" signal is displayed, the alarm is engaged. If you wish to view the zone alarm bar, simply press either the SHALLOW SET or DEEP SET keys and the bar will be displayed for six seconds. It can be turned on permanently by pressing 2nd, downarrow (DISPLAY). To turn it back off, simply press 2nd, downarrow (DISPLAY) again.

If the zone alarm is set off by a fish or the bottom, the alarm will sound and the words ZONE ALARM will flash at the bottom of the display.

If the range is changed, the zone alarm may need to be changed too, since it does not track range settings.

## CLEARING THE ZONE ALARM

To turn the Zone Alarm off, press CLEAR, SHALLOW SET or DEEP SET or press CLEAR, uparrow or downarrow. All of the Zone Alarm settings will remain in memory. Pressing either SHALLOW or DEEP SET keys will turn the Zone Alarm back on with the previous settings.



## NOTE KEY

The note key turns the audible tone off and on. When the X-50 is first turned on, the audible tone is on and a "note" at the bottom of the screen is displayed. To turn the audible tone off, press the note key on the keyboard once. To turn it back on, press the note key again.



## DEPTH ALARM

The Depth Alarm is actually two alarms. The shallow alarm gives a warning when you're in water shallower than the alarm set point. The deep alarm gives a warning in water deeper than the alarm set point. The bottom signal is the only echo that will trigger either the shallow alarm or the deep alarm.

**Note:** The digital must be on in order for the Depth Alarm to function.

By setting both the shallow and deep alarms, a window can be positioned between the surface and the bottom. If the boat goes into water that is shallower than the shallow alarm's set point, the alarm will sound. The same will happen if the boat goes into water deeper than the deep alarm set point. This makes a useful anchor watch or when navigating through a channel.

To use the Shallow Alarm, press the desired depth, then the SHALLOW ALARM key. For example, to set the Shallow Alarm to 15 feet, press 1, 5, SHALLOW SET. The numbers one and five will be displayed on the screen as they are entered, then disappear. The words "DEPTH ALM" will be displayed immediately below the digital depth display to indicate the digital alarm is enabled.

Now, if the boat travels into water shallower than fifteen feet, the shallow alarm will sound with a fast beep tone and the words "DEPTH ALM" will also flash rapidly.

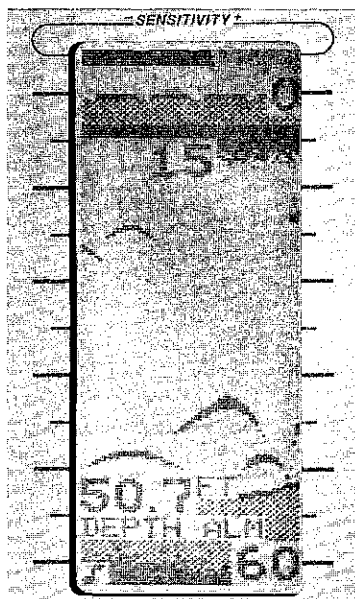

Figure 18

SHALLOW  
ALARM  
SET

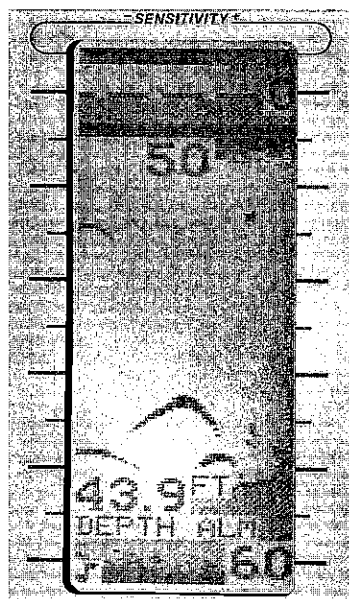

Figure 19

DEEP  
ALARM  
SET

The Deep Alarm can be set in the same manner. Press the desired depth, then the DEEP ALARM key. For example, set the Deep Alarm to 50 feet by pressing 5, 0, DEEP SET. The numbers 5 and 0 will be displayed on the screen as they're entered, then disappear. If the boat moves into water deeper than 50 feet, the alarm will sound with a slow beep tone and the words "DEPTH ALM" will flash slowly.

To view the settings of either the shallow alarm or the deep alarm without changing them, press the SHALLOW ALARM or DEEP ALARM keys.

To clear either the Shallow or Deep Alarm, press 0, SHALLOW ALARM or 0, DEEP ALARM respectively. The words "DEPTH ALM" will disappear from the lower portion of the display, signifying both shallow and deep alarms have been turned off. The CLEAR key can also be used to turn the alarms off. Simply press CLEAR, SHALLOW ALARM or CLEAR, DEEP ALARM to turn each of the alarms off.

**Note:** Both Shallow and Deep Alarms must be off for the words "DEPTH ALM" to be erased from the display.



## LIGHT

Lights behind the display and the keyboard are provided for operation of the X-50 at night. Press the 2nd, AUTO keys to turn the lights on. To turn the lights off, press the 2nd, AUTO keys again. The lights will also go out when the X-50 is turned off. When the X-50 is first turned on, the lights will flash for six seconds to help you find the 2nd, AUTO keys at night.



## DISCRIMINATION

Unwanted noise on the display is a fairly common complaint. Noise can be defined as any undesired signal and it can be caused by either an electrical or acoustic source, or a combination of the two. In both cases, the noise can produce unwanted marks on the display.

The X-50 has Discrimination which is effective in combatting noise signals. It processes all incoming echoes from the receiver, determines which ones are noise and eliminates them, displaying only the legitimate echoes. Discrimination has ten levels—0 through 10. 0 is off, 10 is the highest level. When the X-50 is turned on, the Discrimination is set to level 1. If noise is present on the display, press the level of Discrimination desired, (0, through 10) then the DISC key. There should be an immediate change in the amount of noise displayed on the screen. **Note:** Too much Discrimination will destroy fish arches and fine detail.