

# GLOBALNAV

## INSTALLATION AND OPERATION MANUAL

938-0120-01

**LOWRANCE ELECTRONICS, INC.**  
2000 E. SKELLY DR., TULSA, OK 74128

Copyright © 1991, Lowrance Electronics, Inc.  
All rights reserved.

**WARNING!**

USE THIS GPS RECEIVER ONLY AS AN AID TO NAVIGATION. A CAREFUL NAVIGATOR NEVER RELYS ON ONLY ONE METHOD TO OBTAIN POSITION INFORMATION.

**CAUTION**

This GPS receiver, (like all GPS navigation equipment) will show the shortest, most direct path to a waypoint. It provides navigation data to the waypoint regardless of obstructions. Therefore, the prudent navigator will not only take advantage of all available navigation tools when travelling to a waypoint, but will also visually check to make certain a clear, safe path to the waypoint is always available.

**NOTICE!**

As of this writing, the Department of Defense (DOD) has not declared the GPS navigation system as operational. The system is still in a testing phase. Satellites can be turned off or accuracy can be degraded at will by the system operators. Remember that the GlobalNav, or any GPS receiver is only as accurate as the system it's using.

Features and specifications subject to change without notice.

All display screens in this manual are simulated.

NOTES:

TABLE OF CONTENTS

INTRODUCTION ..... 1  
MOUNTING ..... 1  
POWER CONNECTIONS ..... 1  
GPS MODULE INSTALLATION ..... 3  
    SURFACE MOUNTING ..... 3  
    POLE MOUNT ..... 5  
NOISE ..... 5  
KEYBOARD ..... 6  
GPS -HOW IT WORKS ..... 7  
    ACCURACY ..... 8  
    THE LOWRANCE GPS MODULE ..... 9  
GETTING STARTED ..... 9  
    INITIALIZATION ..... 9  
        INITIAL SETTINGS ..... 10  
        TIME OF DAY ..... 10  
        DATE ..... 11  
        TIME ZONE ..... 11  
        ALTITUDE ..... 12  
        INITIAL POSITION ..... 13  
POSITION/NAVIGATION DISPLAYS ..... 15  
    POSITION DISPLAY ..... 16  
    NAVIGATION DISPLAY ..... 16  
    STEERING SCREEN ..... 17  
        STEERING SETUP ..... 18  
    STATUS DISPLAY ..... 19  
    PLOTTER ..... 21  
        USING THE PLOTTER WITH A WAYPOINT ..... 22  
        PLOTTER MENUS ..... 23  
            ... PLOTTER RADIUS ..... 23  
            ... UPDATE INTERVAL ..... 24  
            ... CLEAR PLOT TRAIL ..... 24  
HOW TO SAVE A WAYPOINT ..... 25  
    SAVING CURRENT POSITION ..... 25  
        WAYPOINT QUICKSAVE ..... 25  
        SAVE AS # ..... 25  
    ENTER NEW WAYPOINT ..... 26  
    VIEW AND SAVE WAYPOINT ..... 27  
    NEW WAYPOINT NUMBER ..... 28  
ERASE A WAYPOINT ..... 29  
GO TO WAYPOINT ..... 30  
WAYPOINT RECALL ..... 30  
    VIEW/GO TO WAYPOINT ..... 31  
    DESTINATION WAYPOINT NUMBER ..... 32  
ROUTES ..... 32  
    CREATING A ROUTE ..... 33  
    FOLLOWING A ROUTE ..... 35  
    CANCELLING A ROUTE ..... 37  
    ERASING A ROUTE ..... 37  
GPS ALARMS ..... 38  
    ARRIVAL ALARM ..... 38  
    C.D.I. ALARM ..... 38  
    ALARM MUTE ..... 39  
UNITS OF MEASURE ..... 39  
NMEA COMMUNICATION ..... 40  
SPEAKER VOLUME ..... 41  
DISPLAY CONTRAST ..... 42  
LIGHT ..... 42  
MEMORY-PRESET ..... 43  
SYSTEM INFORMATION ..... 44  
PCF OFFSET (Position Correction Factor) ..... 44  
    Set as Position ..... 45  
    Set as Offset ..... 46  
MAN OVERBOARD ..... 47  
SPECIFICATIONS ..... 48

NOTES:

NOTES:

## NOTES:

## INTRODUCTION

The GlobalNav represents one of the best values in GPS receivers today. It rivals other GPS units costing much more in both features and performance. The GlobalNav offers easy-to-use operation at the touch of a button.

Although the GlobalNav has many features and functions, the "soft key" menu system makes it easy to use. Above all, don't be afraid to try different features and functions on the unit. You can't hurt it by pressing buttons!

Read this manual and take it with you the first few times you use your unit. It makes a great reference should you need it. The more you know when you get to the water, the more your GlobalNav can do for you!

## MOUNTING

Install the GlobalNav in any convenient location, provided there is clearance behind the unit when it is tilted for the best viewing angle. Holes in the bracket base allow wood screw or through-bolt mounting. You may need to place a piece of plywood on the back of thin fiberglass panels to secure the mounting hardware. Make certain there is enough room behind the unit to attach the power and GPS cables.

The smallest hole that will pass the GPS module's connector is 9/16". After drilling the hole, pass the GPS connector up through the hole first, then pass the power cable down through it.

After the cables have been routed, fill the hole with a good marine sealing compound. Offset the bracket to cover the hole.

## POWER CONNECTIONS

The GlobalNav works from a twelve-volt battery system only. You can attach the power cable to an accessory or power buss, however if you have problems with electrical interference, then attach the power cable directly to the battery. If the cable is not long enough, splice #18 gauge wire onto it.

The power cable has three wires; red, white, and black. Red is the positive lead, black is negative or ground. Attach the in-line fuse holder to the red lead as close to the power source as

possible. For example, if you have to extend the power cable to the battery or power buss, attach the fuse holder directly to the battery or power buss. This will protect both the unit and the power cable in the event of a short. The white wire is for a NMEA interface. The GlobalNav sends data for another electronic navigation devices through this wire. If the white wire is not used, tape the end so that it cannot short.

To connect a device to the GlobalNav's NMEA output, attach a shielded, twisted pair cable from the device's NMEA input to the white wire on the GlobalNav's power cable. Solder the ground conductor of the twisted pair and the shield to the black wire on the power cable. Do not connect the shield to the other device. See the other instrument's manual for more wiring instructions.

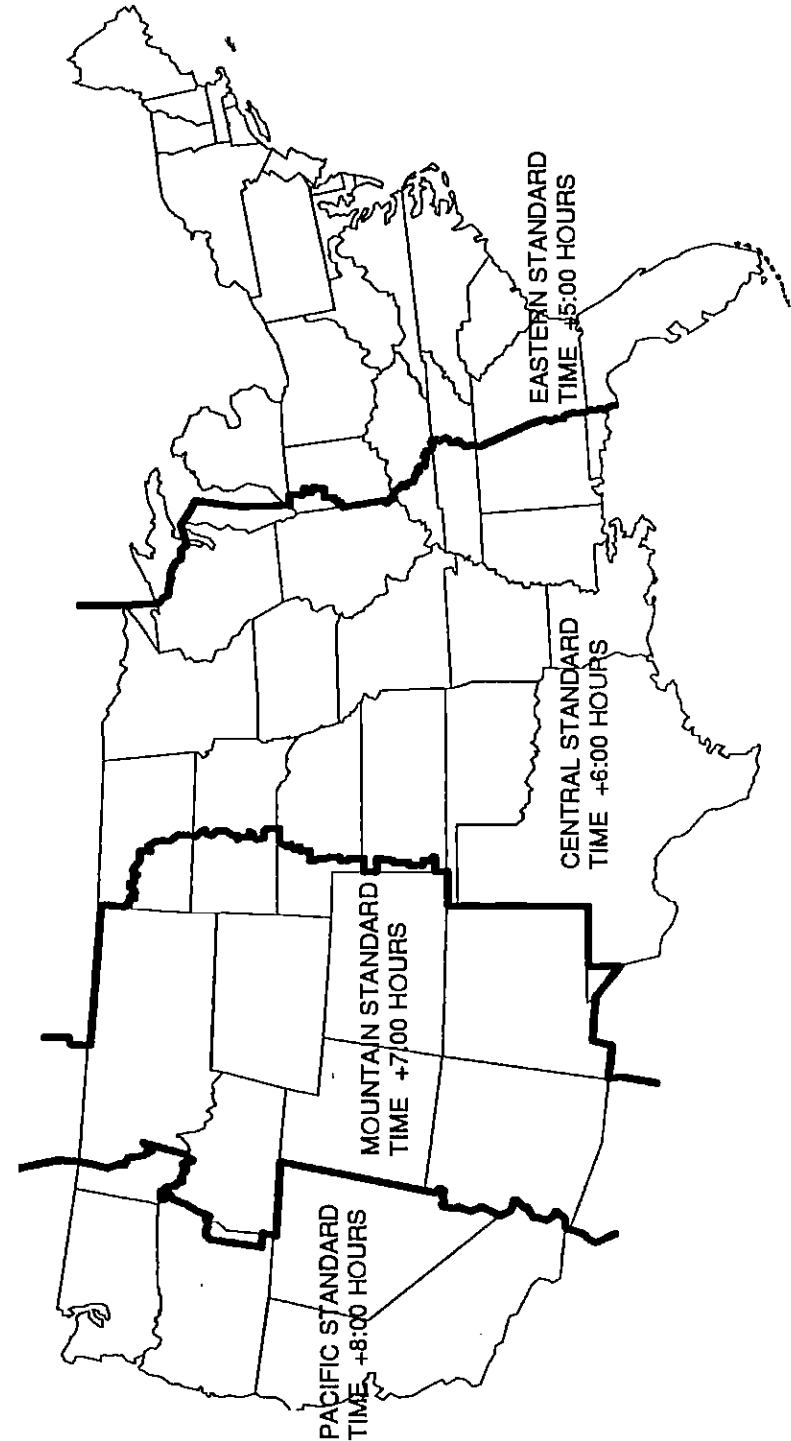
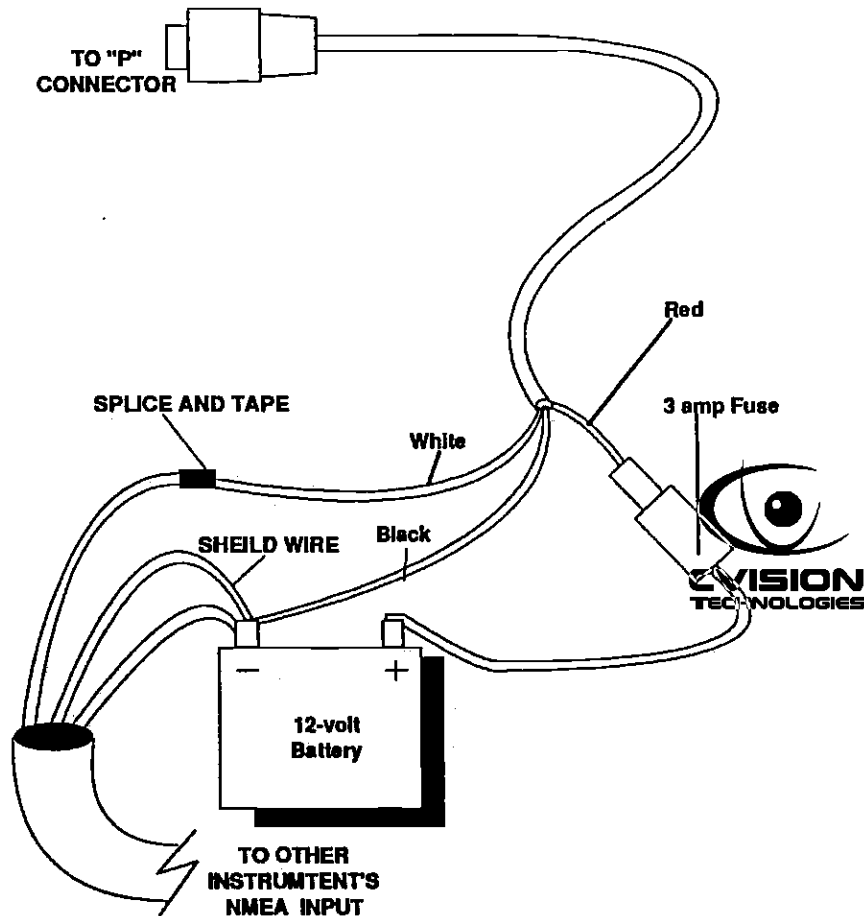

See the NMEA section in this manual for more information. The GlobalNav automatically sends NMEA data out the white wire once it acquires and "locks on" to the satellites.

### GPS MODULE INSTALLATION

The GPS module can be installed on a flat surface or (with the supplied adapter) on a pole. Mount the module in an area that guarantees a clear view of the sky at all times. In order for the module to receive the signals from the satellites, it must not be obstructed. An ideal location is on a cabin roof, or deck. The gunnels also make a good location. Attaching the pole mounting adapter lets you install the module on a one inch mast. A high location is preferred. However, for lightning protection, the antenna shouldn't be the highest part of the boat.

### Surface Mounting - With Access

If you have access underneath the mounting surface, use the gasket supplied with the GPS module as a template. Drill four 7/32" holes and one 9/16" hole for the module's cable. Attach the cable to the module and pass it down through the hole in the gasket and the mounting surface. Use #10-32 machine screws (not included) to fasten the GPS module to the mounting surface. Route the cable to the GlobalNav.

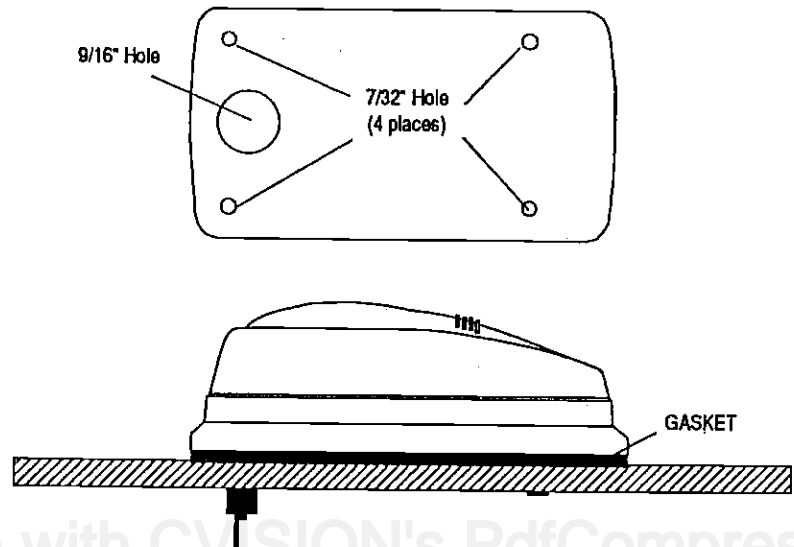

## Surface Mounting - Without Access

If you don't have access to the back side of the mounting surface, use the "cleats" supplied with the GlobalNav. (Note: This is assuming you can "snake" the module's cable to a location that is accessible. A hole will still need to be drilled in the mounting surface for the cable.) Using the gasket as a template, mark and drill the 9/16" hole for the cable. Attach the cable to the module and drop the other end of the cable through the gasket and down the hole. Place the module on the gasket. Slide the "cleats" onto each end of the module and (using the cleats as templates) mark four holes for #10 mounting screws. Drill the holes, then replace the cleats on the module and fasten them to the mounting surface with #10 screws. Route the cable to the GlobalNav.

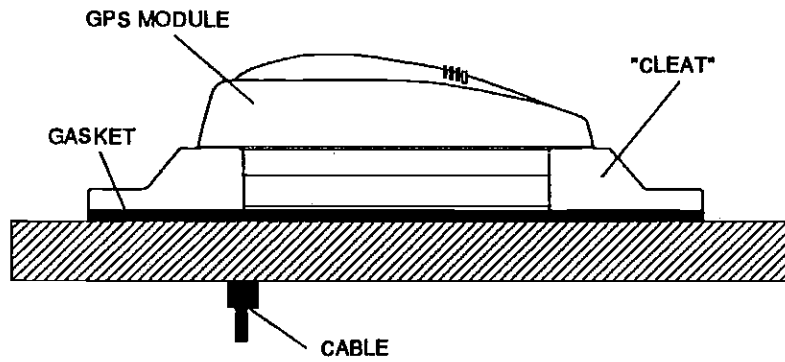
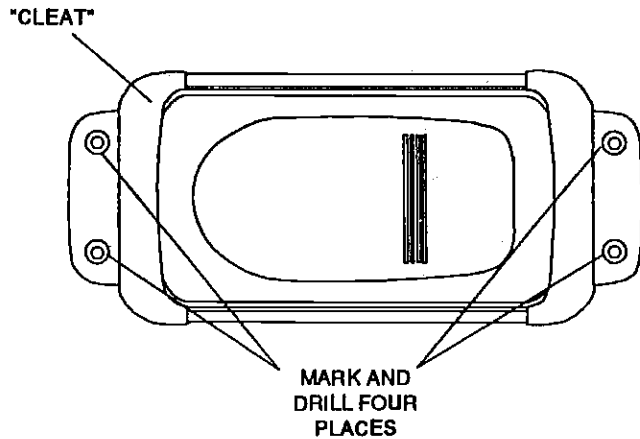

## GLOBALNAV GPS RECEIVER SPECIFICATIONS

GPS Module Dimensions ..2.5"H x 4.1"W x 7" D

Channels ..... Five Parallel  
Four continuous for position  
All satellites in view tracked

Update rate ..... One second

Accuracy ..... Maximum accuracy achievable  
with Standard Positioning Service  
Position: 25 meters CEP  
Velocity: 0.25 meters/sec RMS  
Without SA PDOP < 6.0

## NMEA 0183 SENTENCES

RMB ..... Minimum Recommended Sentence,  
Part B

RMC ..... Minimum Recommended Sentence,  
Part C

GLL ..... Present Position - Latitude/Longitude

APA ..... Autopilot Steering Data

DBK ..... Water Depth

MTW ..... Water Temperature (°C)

VHW ..... Speed Through Water (KPH)

VLW ..... Distance Travelled/LOG (NM)

## GLOBALNAV GPS RECEIVER SPECIFICATIONS

GPS Module Dimensions .. 2.5"H x 4.1"W x 7" D

Channels ..... Five Parallel  
Four continuous for position  
All satellites in view tracked

Update rate ..... One second

Accuracy ..... Maximum accuracy achievable  
with Standard Positioning Service  
Position: 25 meters CEP  
Velocity: 0.25 meters/sec RMS  
Without SA PDOP<6.0

## NMEA 0183 SENTENCES

RMB ..... Minimum Recommended Sentence,  
Part B

RMC ..... Minimum Recommended Sentence,  
Part C

GLL ..... Present Position - Latitude/Longitude

APA ..... Autopilot Steering Data

DBK ..... Water Depth

MTW ..... Water Temperature (°C)

VHW ..... Speed Through Water (KPH)

VLW ..... Distance Travelled/LOG (NM)

## Pole Mount

First attach the GPS module's cable to the module. Next, pass the cable through the pole mounting adapter. Attach the adapter to the GPS module with the four stainless steel screws supplied with the GlobalNav. Now pass the cable through the mounting pipe. The mounting adapter is threaded for standard 1"-14 machine thread. (Not pipe thread.) Thread the mounting pipe onto the GPS module/pole adapter assembly. After tightening the threads, install the supplied set screw into the front of the pole mounting adapter and tighten it. This should prevent the GPS module from unscrewing from the pole.

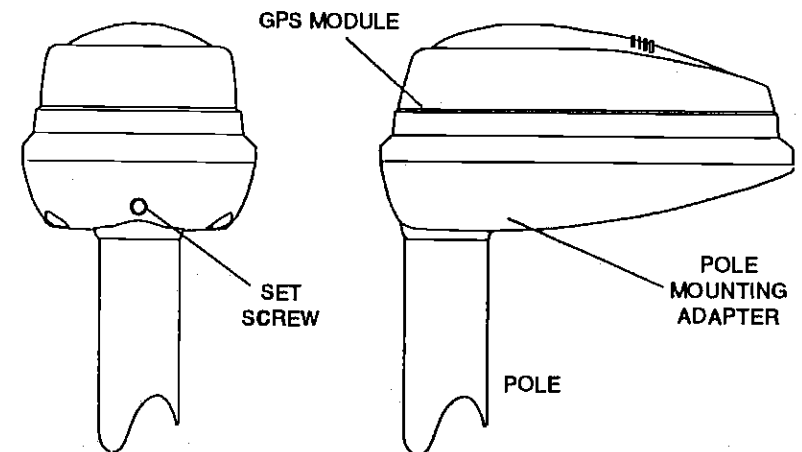

## NOISE

Minimize electrical noise problems by routing the power and GPS module cables away from other sources of electrical noise. These include engine alternators and wiring harness, spark plug wires, and power generators. Some VHF radio antennas and their cables also radiate noise when transmitting. Bilge pumps are usually very noisy when operating. It's important to keep the GlobalNav's cables away from these items, also.

## KEYBOARD

The keyboard has keys arranged in two vertical columns. The keys in the left column are used for saving and recalling waypoints. The keys in the right column pertain to the basic GPS functions. The MENU key in the bottom right corner of the keyboard activates the first menu page.

**POS** - Pressing this key displays the Position screen.

**PLOT** - This switches the GlobalNav into the plotter mode.

**NAV** - Pressing this key displays the Navigation screen.

**STEER** - This displays the Steering screen.

**MENU** - Press this key to show the menus and gain access to other functions.

**ON** - The ON key turns the GlobalNav on.

**WAYPT QUICKSAVE** - Pressing this key instantly saves your present position.

**WAYPOINT SAVE** - This feature gives you more waypoint saving options.

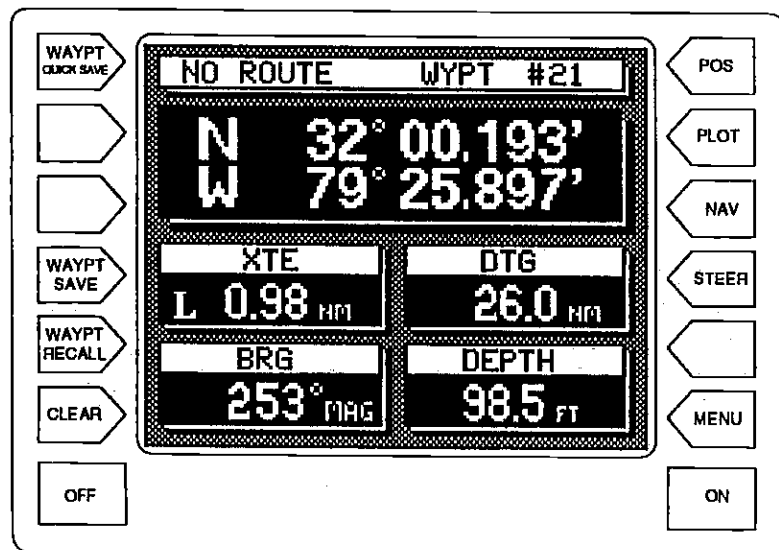

## MAN OVERBOARD

One of boating's most terrifying events is having a friend or family member fall overboard. This situation can be deadly on any body of water, fresh or salt. It's particularly dangerous at night or if you're out of sight of land. Of course, the first thing to do is remain calm and try all standard safety measures to try and rescue the person. If you lose sight of the person, you can use the GlobalNav to initiate a search pattern.

Once you're back at the helm after initial rescue efforts have failed, press the GlobalNav's Waypoint Quicksave key. This instantly stores your present position in memory. Memorize the waypoint number that appears at the top of the screen! Now press the Waypoint Recall key. Press the key next to the "Dest. Waypt Num." near the bottom of the screen. A new menu appears. Enter the waypoint number that you just saved, then press the key adjacent to the "ENTER" label. This recalls the waypoint you stored, causing the GlobalNav to show navigation information back to that waypoint. The Arrival alarm will sound since you're within it's radius, either ignore it or press the CLEAR key to silence it.

Using the unit in this manner lets you start a search pattern for the victim from a known location. Switching to the plotter on the .05 mile range makes it easier to see your position relative to the accident area.

Remember, saving the victim is the primary goal. Try all options to rescue the person immediately after the accident happens. Training and education are also good accident preventatives. The Coast Guard has excellent safety courses. Instruct all members on board your boat on safety procedures before leaving the dock. Make certain all on board know what to do before any emergency occurs.

For more information on saving and recalling waypoints, see "How to Save a Waypoint" section in this manual.

key adjacent to the "Use Position" label. The GlobalNav returns to the last used position, navigation, or plotter screen using the offset information you entered. To verify that PCF is in effect, switch to the position, navigation, or plotter screen. The letters "PCF" appear on these screens when PCF is enabled.

### Set as Offset

To enter the offset or difference in position from your present position and the one on the chart, first subtract your current position from the location on the chart you wish to match. For example, if your location is N 32°10.220', W 80°12.106' and the chart's position is N 32°15.604', W 080°12.714, then the position offset is N 00°05.384, W 00°00.608'. Ppress the MENU key, then press the key adjacent to the "More" label until the "PCF Adjustment" label appears. Press the key adjacent to that label. The screen shown at the top of the previous page appears.

Now press the key adjacent to the "Set as Offset" label. The screen shown below left appears. Enter the difference between your position and the chart's location in latitude and longitude. After pressing the key adjacent to that label, the screen shown below right appears.

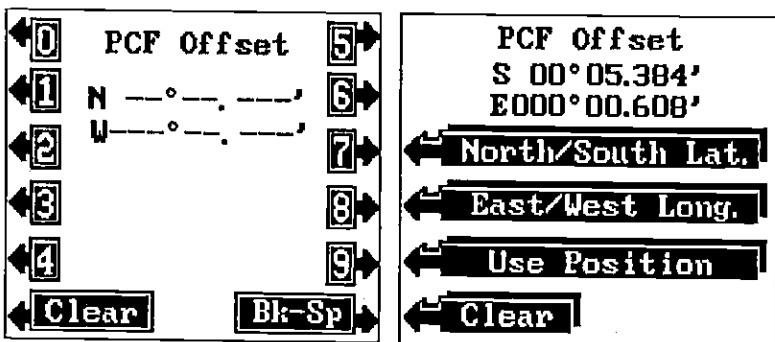

If you need to switch the latitude from north to south, press the key adjacent to the "North/South Lat." label. Switch the longitude if necessary in the same manner by pressing the key next to the "East/West Long." label. If the offset shown at the top of the screen is correct, press the key adjacent to the "Use Position" label. The GlobalNav returns to the last used position, navigation, or plotter screen using the offset information you entered. To verify that PCF is in effect, switch to the position, navigation, or plotter screen. The letters "PCF" appear on these screens when PCF is enabled.

**WAYPOINT RECALL** - This key is used to recall waypoints from memory.

**CLEAR** - Use this key to exit from menus

**OFF** - The Off key turns the GlobalNav off.

### GPS - HOW IT WORKS

The Global Positioning System (GPS) is the newest, most high-tech approach to navigation yet devised. Conceived by the Department of Defence (DOD) and the United States military, the GPS system is an answer to their needs of 24 hour global positioning, 365 days a year.

Basically, the system works by using a constellation of satellites orbiting Earth 11,000 miles in space. There will be 21 satellites in orbit when the system is fully operational. Three more satellites will act as spares, for a total of 24. When all satellites are in place, at least four of them will be in view nearly anywhere on Earth twenty four hours a day. The GPS receiver requires at least three satellites to give a "2D" fix. (A 2D fix is your position in latitude/longitude. A 3D fix is your latitude/longitude plus altitude.) When the GlobalNav locks on to at least four satellites, it displays a 3D fix.

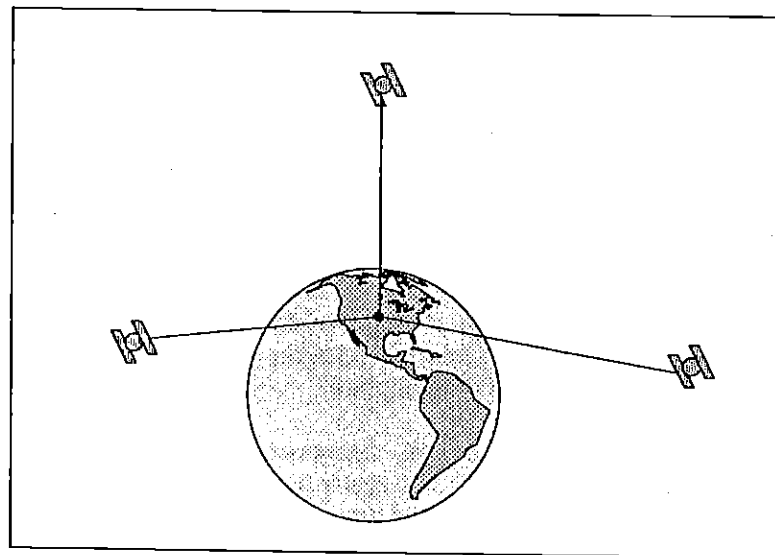

Three GPS satellites to determine position

As the receiver locks on to each satellite, it calculates the distance from the satellite by measuring the length of time it takes the radio signal to reach it. The satellites have an extremely accurate clock and it tells the receiver when the radio transmission started. The receiver compares that time against its own clock, thus it knows how long it took the radio signal (travelling at the speed of light!) to reach it. If you know time and speed, then you can calculate distance. Once you have this from three satellites, then the receiver can determine position.

## ACCURACY

Most of us have heard tales of extraordinary accuracy from GPS receivers. The DOD requires accuracy of 10 to 15 meters from the satellite system. However, only the military gets this precision. The way the military keeps us and other unauthorized people from using the more precise system is coding. In other words, the data coming from the satellites is encrypted. Civilian GPS receivers use what's known as "C/A Code." It's intentionally worse than the military's "P Code." In this manner, civilian users worldwide can benefit from excellent position fixes. Meanwhile, the military keeps the most accurate system away from potential enemies. Theoretically, C/A code can give accurate position fixes up to 15 meters. This is more than adequate for most people.

However (as of this writing), the military isn't satisfied with C/A's potential accuracy in the hands of the world. So, it's degrading it further with what's called "Selective Availability" or SA. This is small, random errors intentionally added to the system so your accuracy will typically be within 100 meters. Of course, accuracy also depends on the angle of the satellite above the horizon, signal-to-noise ratio, the number of satellites tracked at one time (the more the better), and other factors.

Don't let this discourage you, however. Our tests have repeatedly shown better than 100 meter accuracy. Furthermore, GPS by nature has much faster updates than other systems (such as Loran), and typically is much easier to use. You've purchased one of the finest navigation instruments on the market today. We hope you'll enjoy it for many years to come.

The GlobalNav gives you a choice of methods to enter the PCF. The first method (Set as Position) lets you simply enter the corrected latitude/longitude. The second method (Set as Offset) requires a calculation be performed, then entered into the GlobalNav.

## Set as Position

To use the Set as Position method, first choose the location on the chart that you wish to match the unit's position display to. Then move the boat to that position and hold it there as accurately as possible. Now press the MENU key, then the key adjacent to the "More" label until the "PCF Adjustment" label appears. Press the key adjacent to that label. The screen shown below appears.

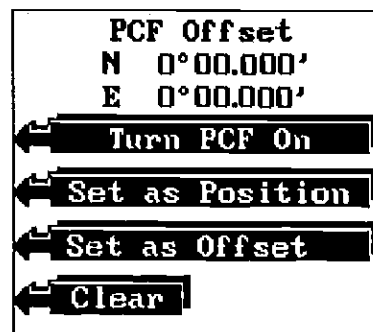

Now press the key adjacent to the "Set as Position" label. The screen shown below left appears.

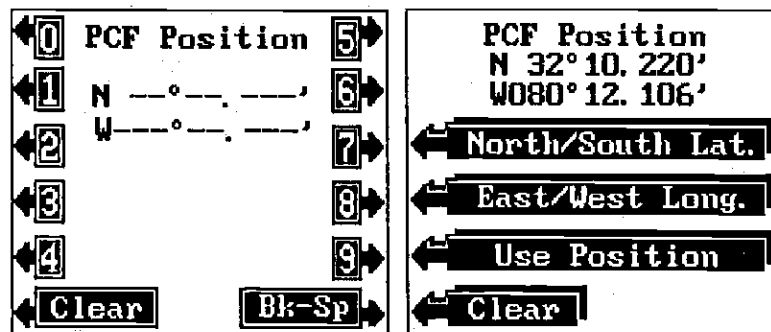

Now enter the position shown on the chart. After the last key is pressed, the screen shown above right appears. Press the key adjacent to the "North/South Lat." label to switch the latitude from north to south. Switch the longitude in necessary in the same manner by pressing the key next to the "East/West Long." label. If the position shown at the top of the screen is correct, press the

## SYSTEM INFORMATION

The code contained in the GlobalNav is numbered. This information can be obtained by pressing the MENU key, then the key adjacent to the MORE label two times. Next, press the key adjacent to the "System Info" label. A message similar to the one below will be displayed.

GlobalNav  
Version: 1.0  
Copyright 1991  
Lowrance Electronics

Press the key adjacent to the CLEAR label to erase this message and return to the sonar screen.

## PCF OFFSET (Position Correction Factor)

The GPS navigation system relies on complex mathematical calculations to determine your position based on satellite data and other factors. One factor is the Earth's shape. Since the Earth is not a true sphere, variations in the calculations have to be made to accommodate deviations. To make matters more complex, not everyone uses the same data to determine what the deviations are. The size and shape of the ellipsoids that are used to approximate the earth's surface are improved often. This can lead to errors if your navigation device uses one ellipsoid, while your chart uses a different one. The term used for these ellipsoids is "datum."

To reduce the error factor between datum, the UltraNavGPS gives you the capability to move or "offset" the position shown on the display to match one shown on the chart. The unit will add this offset to all position displays at all times.

For example, suppose you are anchored at a location that is accurately marked on a chart. Your GlobalNav displays a longitude position that is .010 degrees less than the one on the chart. Using the Position Correction Factor (PCF) Offset feature, you make the GlobalNav read the same as the chart. If you raise anchor and move, the GlobalNav will add the change you made to all positions. This makes it more closely match the datum used by the chart. For this reason, you should be careful when entering the PCF Offset. This is saved in memory. It does not change when the unit is turned off. However, Preset does erase the PCF settings.

## The Lowrance GPS Module

This GPS receiver (manufactured by Rockwell) currently is used in all Lowrance GPS receivers. It's small, rugged, and fast. The five channel design lets it acquire and track up to all satellites in view at all times. It transmits position information to the GlobalNav once every second. By incorporating Rockwell's GPS receiver technology with Lowrance's state-of-the-art design and manufacturing capabilities, Lowrance brings you the most advanced line of GPS navigation systems available in the world.

## GETTING STARTED

### Initialization - Power On

The GlobalNav must be initialized or "told where it is" the first time it's turned on. This initialization process is usually done only once and requires the following data:

1. Present position in latitude/longitude
2. Elevation above sea level (altitude)
3. Today's date and time
4. Number of hours from Greenwich, England (UTC)

Every time the GlobalNav is turned on, the screen shown below appears. This shows the data that the GPS module will start with at power on. This is needed by the GlobalNav to tell the GPS module which satellites are visible so it can determine your position faster. Please check it every time you turn the unit on to make certain that it is correct. If it is correct, simply press the CLEAR key to erase the screen.

TIME OF DAY	11:30 am
DATE	8/27/1991
TIME ZONE	+00:00
ALTITUDE	+ 0ft
INITIAL POSITION	N 00°00.000' W 00°00.000'
← Lamp	VERIFY SETUP: CLEAR IF OK.
← Clear	Change →

If you need to change any of this data, press the key adjacent to the "Change" label. The very first time you use the GlobalNav, you'll need to press this key. After pressing it, the screen shown below appears.

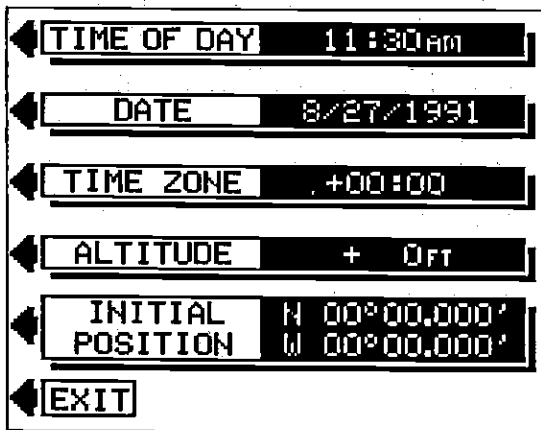

## INITIAL SETTINGS

This screen lets you change some or all of the initial values. For example, when the time goes from standard to daylight savings time, you'll need to change the Time Of Day and Time Zone settings. A description of each section follows.

### TIME OF DAY

The time of day is simply the present time at your location. If the time on the screen is wrong, then press the key adjacent to the "TIME OF DAY" label. The screen shown below appears.

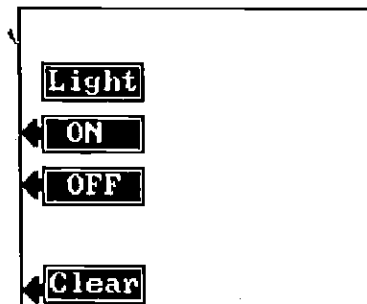
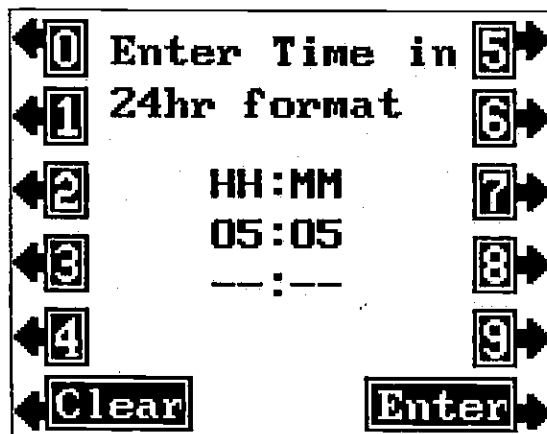

The light menu also appears each time the GlobalNav is turned on. The lights and the menu will turn themselves off after a few seconds unless the key adjacent to the ON key is pressed. This makes it easier to turn the lights on at night.

## MEMORY - PRESET

The GlobalNav saves all settings such as units of measure, contrast setting, alarm settings, and more in battery-backed-up memory. This memory is retained even if power is disconnected from the unit. If you need to return the unit to the factory settings, use the Preset function.

### IMPORTANT!

**Preset returns all GPS settings to zero. The GPS will have to be re-initialized after a Preset!**

To do this, press the MENU key, then press the key adjacent to the MORE label three times. Now press the key adjacent to the Preset label. A warning label appears as shown below. When presetting a unit, navigation to waypoints and routes is cancelled. Now press the key adjacent to the Preset label to continue. The screen will clear and the message "System Powering Up. Please Wait" may appear for a few seconds. Then the GlobalNav will display the initial settings screen, and all features will return to their factory settings.

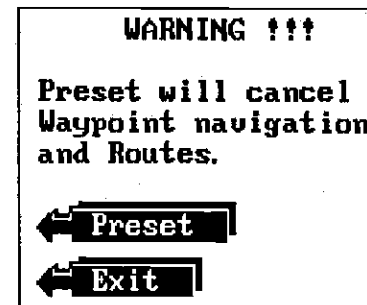

## DISPLAY CONTRAST

The contrast of the display can be changed for easier reading in different light conditions.

To change the contrast, press the MENU key. Next, press the key adjacent to the MORE label three times. Now press the key adjacent to the Display Contrast label. The Disp. menu appears. Press the key adjacent to the up arrow to increase the display contrast. The key adjacent to the down arrow decreases it. The bar graph changes with your selection. The number in the menu box also changes. There are 31 steps of contrast available. Press the CLEAR key to erase the menu.

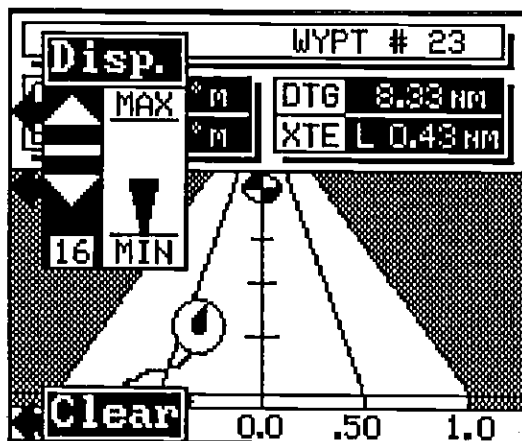

DISPLAY CONTRAST MENU

## LIGHT

The keyboard and display are backlit for night use. Turn the lights on and off from the Light menu.

To turn the lights on or off, press the MENU key. Next, press the key adjacent to the "Lamp" label. This displays the light menus. Press the key adjacent to the ON label to turn the lights on. Press the key adjacent to the OFF label to turn the lights off. Press the CLEAR key to erase the menu.

Enter your local time in 24 hour format using the keys on both sides of the screen. For example, if your watch reads 2:00 in the afternoon, then you will enter 14:00. Twelve o'clock noon is 12:00, midnight is 24:00. After you've entered your local time, press the key next to the "Enter" label.

The GlobalNav returns to the initial setup menu.

## DATE

The next setup item is today's date. Press the key adjacent to the "DATE" label to change the displayed date. The screen shown below appears.

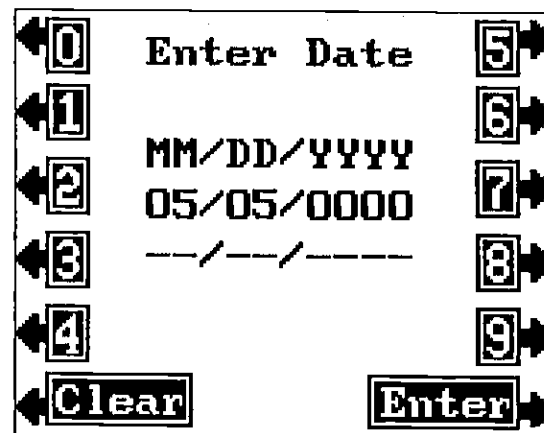

Now enter the month, then today's date, and finally the year. For example, if the date is October 22, 1991, then enter 10/22/1991. After entering the date, press the key adjacent to the "Enter" label. The GlobalNav returns to the initial setup menu.

## TIME ZONE

The time zone is the difference between your time and UTC in hours and minutes. UTC stands for Universal Coordinated Time. It used to be called Greenwich Mean Time or GMT. No matter what you call it, this is the time at Greenwich, England. The GlobalNav needs to know this time since the system works off of UTC time, not local. If you're west of Greenwich, use a positive number. Use a negative number if you're east of Greenwich. A time zone map for the continental United States is in the back of this manual.

The time zones for the Continental United States are:

Time Zone	Enter
Eastern Standard Time (EST)	+5:00
Central Standard Time (CST)	+6:00
Mountain Standard Time (MST)	+7:00
Pacific Standard Time (PST)	+8:00

NOTE: Don't forget to change the time by one hour if daylight savings time is in effect. For example, Eastern Daylight Savings Time becomes +6:00. Remember to change both local time and Time Zone when changing to or from Daylight Savings Time.

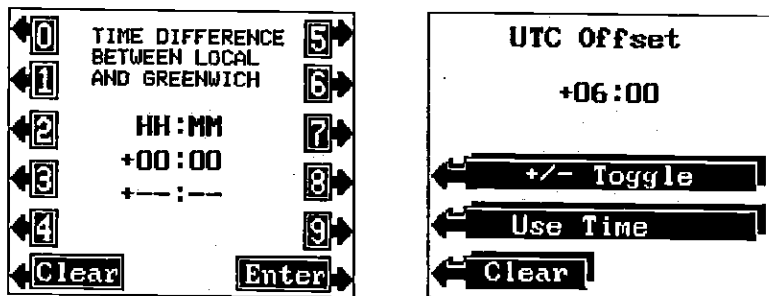

To enter the Time Zone, press the key adjacent to the TIME ZONE label. The screen shown above left appears. Now enter the difference in time between UTC and your local time. When you're finished, press the key next to the "Enter" label. The screen shown above right appears next.

If the UTC offset shown on this page is correct, press the key adjacent to the "Use Time" label. If you need to change the offset from positive to negative, press the key next to the "+/- Toggle", then press the key next to the "Use Time" label. To exit from this menu without changing the time offset, press the key adjacent to the "Clear" label.

## ALTITUDE

The next parameter the GlobalNav needs is your altitude. This is the distance from the GPS module to sea level in feet. The altitude doesn't have to be precise in order for the GPS receiver to find your position. For example, if you're on the ocean, enter 0 feet. If you're in Tulsa, Oklahoma, enter 675 feet. That's the elevation of Tulsa at the airport. (Calling your local airport is the easiest way to find both altitude and your present position. Remember, however to ask for elevation, not altitude.) Now press the key adjacent to the Altitude label. The screen shown at the top of the next page appears.

First, press the MENU key. Next, press the key next to the "More" label until the NMEA label appears. Press the key next to this label. The screen shown at the top of the next page appears. The data format currently in use shows at the top of the screen. Press the key adjacent to the desired data output. The GlobalNav will return to the last used GPS or plotter screen, and send NMEA data out the white wire on the power cable.

## SPEAKER VOLUME

The speaker volume is adjustable. You can make it louder so you can hear alarms or the "beep" each time you press the key in noisy surroundings. Or you can turn it down in quiet situations.

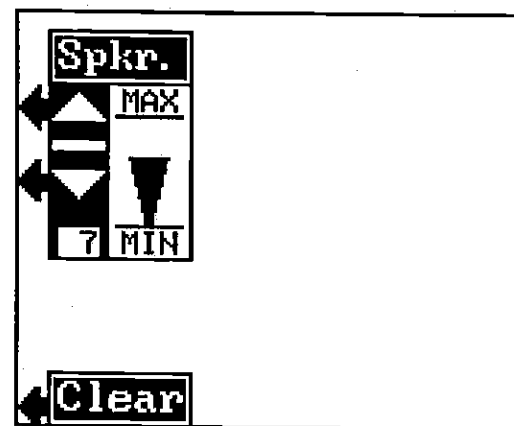

To adjust the speaker volume, press the MENU key. Next, press the key adjacent to the MORE label until the Speaker Volume label appears. Now press the key adjacent to the Speaker Volume label. The Speaker menu appears on the left side of the display. Use the key adjacent to the up arrow to increase the volume or the key adjacent to the down arrow to decrease it. The bar graph will increase or decrease corresponding to the change you make. The number in the menu's box will also change. When the GlobalNav is first turned on, the speaker volume is set to 7. The range is 1 to 10.

The unit of measure for all of the items on this menu are shown on this screen. To change one or all, simply press the key adjacent to the label that you wish to change. For example, to change Distance from miles to nautical miles, press the key next to the "Distance" label until the label reads "Distance = NM." You can change the units of measure for all of the items on this screen at the same time.

When you've modified the units of measure to the desired settings, press the CLEAR key. The GlobalNav reverts to the last used navigation screen using the changes you made.

### NMEA COMMUNICATION

The GlobalNav sends data out the white wire on the power cable according to standards set by the NMEA (National Marine Electronics Association). This allows the GlobalNav to send position, depth, and navigation information to "listener" units, such as charting instruments, autopilots, and other marine instruments. The GlobalNav uses the following NMEA data protocols: NMEA 0180, 0182, and 0183. NMEA 0180 sends steering information only. It's useful mainly for autopilots. NMEA 0183 has the most information, sending position, steering, speed, and more. In order to use this feature, the white wire on the power cable must be connected to the NMEA data input on the other instrument. See the installation section at the front of this manual for wiring connection information.

Once the wiring is connected properly, the GlobalNav must be told which data format to use. Consult the owner's manual of the "listener" equipment to see the which format it needs. Then set the GlobalNav as follows:

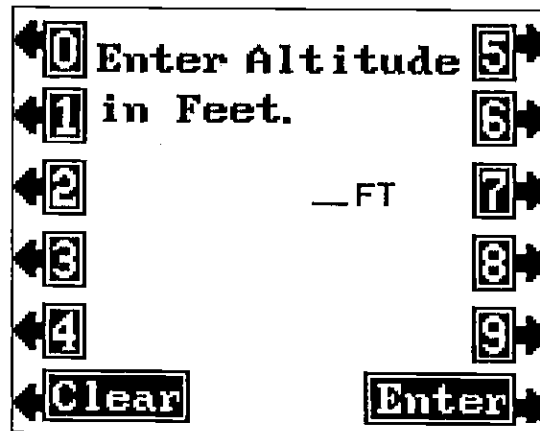
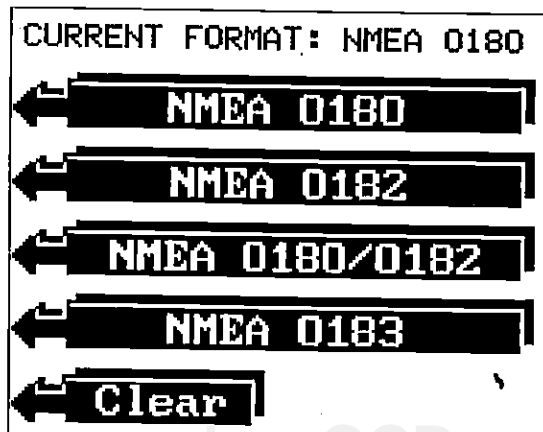

Now enter your Altitude using the keys on both sides of the screen. After you've entered the numbers, a new screen appears as shown below. This lets you switch the numbers from positive to negative. In other words, use positive altitude when you're above sea level, use negative numbers if you're below it. Once the numbers on the display are correct, press the key adjacent to the "Use Position" label. The GlobalNav then returns to the Initial Settings screen.

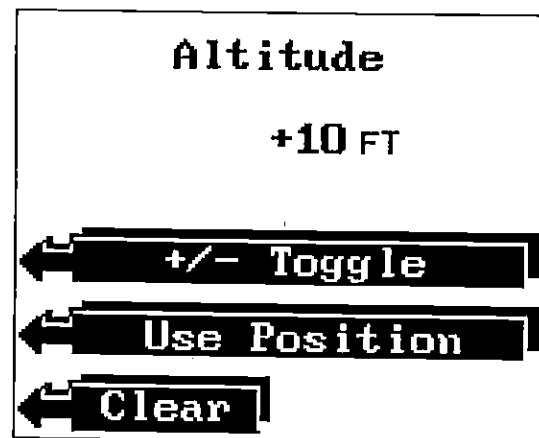

### INITIAL POSITION

The last piece of information the GlobalNav needs to start is your present position in latitude/longitude. First, press the key adjacent to the "INITIAL POSITION" label. The screen shown at the top of the next page appears.

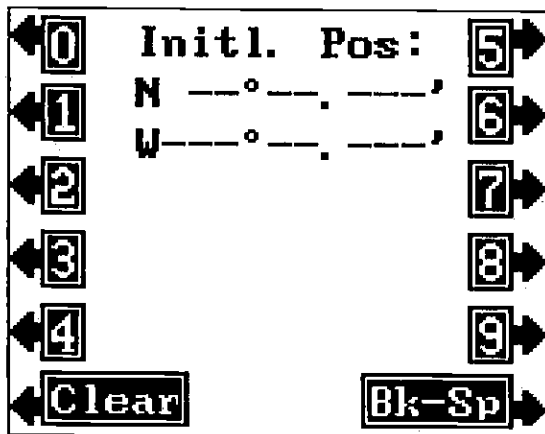

Now enter your latitude and longitude using the keys on both sides of the screen. Remember to add a zero to the longitude if it's less than 100 degrees. For example, if your longitude is 81 degrees, then enter 081.

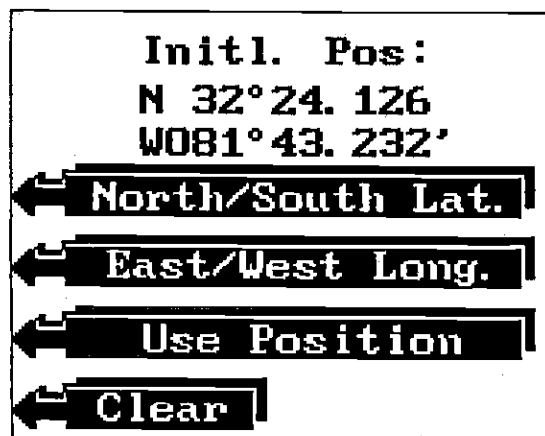

After entering the position, the screen shown above appears.

Press the key adjacent to the North/South label to change the latitude from north to south, if necessary. Likewise, press the key adjacent to the East/West label to change the longitude. When the initial position is correct, press the key adjacent to the "Use Position" label. The GlobalNav returns to the Initial Settings screen.

To set the XTE alarm, press the MENU key, then press the key adjacent to the "More" label until the "Set Alarms" label appears. Now press the key adjacent to that label. The screen on the opposite page appears. Press the key adjacent to the up arrow in the XTE alarm's menu to increase the alarm's range. Press the key next to the down arrow to decrease it. The XTE alarm's range is from .01 to 10 miles.

To turn the XTE alarm off, press the key next to the down arrow until the word "OFF" appears.

Press the CLEAR key to exit from the GPS alarm menu.

### ALARM MUTE

When any alarm sounds, the "Press Clear key to Mute" message appears at the top of the screen. Pressing the CLEAR key silences the speaker until the alarm is tripped again. This doesn't turn the alarm off, it merely shuts the speaker off temporarily.

### UNITS OF MEASURE

The GlobalNav can display distance, speed, altitude, degrees, and time in different units of measure. For example, distance can be displayed in statute miles, nautical miles, or kilometers.

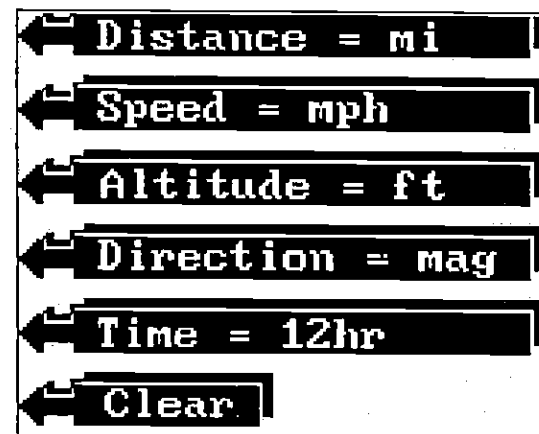

To change the units of measure, first press the MENU key, then press the key next to the "More" label until the "Change Units" label appears. Now press the key adjacent to the "Change Units" label. The screen shown above appears.

## GPS ALARMS

The GlobalNav has two GPS alarms; a CDI alarm and an Arrival alarm. The CDI alarm sounds an audible tone when the CDI indicator moves past a preset limit. Both alarms are set and adjusted from the same menu.

### ARRIVAL ALARM

The arrival alarm sounds a tone when your position is within the alarm's radius of a waypoint. For example, if the alarm's setting is .5 mile, then the alarm sounds a tone when you come within .5 miles of a waypoint.

To set the arrival alarm, first press the MENU key, then press the key next to the "More" label until the "Set Alarms" label appears. Now press the key adjacent to that label. The screen below appears. Press the key adjacent to the up arrow in the arrival alarm's menu to increase the alarm's radius. Press the key next to the down arrow to decrease it. The arrival alarm's range is from .01 to 10 miles.

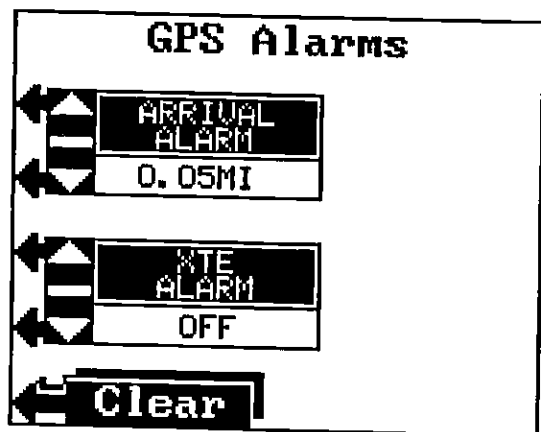

To turn the arrival alarm off, press the key next to the down arrow until the word "OFF" appears.

### XTE ALARM

The XTE alarm sounds a tone when the cross track error exceeds the alarm's setting. For example, if the alarm is set to .5 nautical miles, the alarm will sound if you go off course by more than .5 mile.

The initial setup is now complete. Press the CLEAR key. The GPS position screen appears with the present position display flashing. The GlobalNav begins its search for the correct satellites. Once it locks onto at least three of them, your position displays. The latitude/longitude position will stop flashing when the GlobalNav has locked onto the necessary satellites. To view the satellite data, see the Satellite Status section in this manual.

### WARNING!

Never navigate with this unit when the position screen flashes the latitude/longitude! This means the unit is not usable for navigation. Always use more than one method to navigate.

If you move a long distance from the last time you used the GlobalNav, you may need to re-initialize the unit. If you preset the GlobalNav, you will definitely need to re-initialize the unit. The "Initial Setup" menu selection on the GPS' second menu page returns you to the initial setup menu, when needed. Otherwise, you shouldn't need to repeat these steps.

### POSITION/NAVIGATION DISPLAYS

The GlobalNav has five main display modes. These are the Position, Navigation, Steering, Plotter, and Status displays.

To view any of the first four displays, simply press the key with the respective label. In other words, to view the Navigation screen, simply press the NAV key. The screen shown below appears. To view the Status screen, press the MENU key, then key adjacent to the Status screen's label. A description of each screen follows.

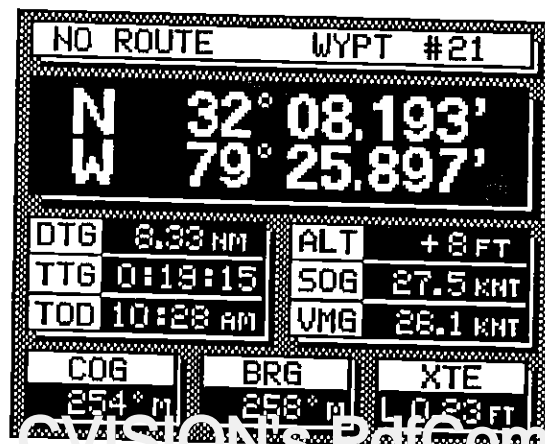

## Position Display

The Position display shows your present position in latitude/longitude coordinates. This is displayed in degrees, minutes, and thousands of a minute. (Not seconds.) Beneath the present position display is Course Over Ground (COG), Cross Track Error (XTE), Distance To Go (DTG), and Bearing to waypoint (BRG). Cross Track Error, Distance To Go, and Bearing are used only when a waypoint is recalled. See the section on waypoints for more information.

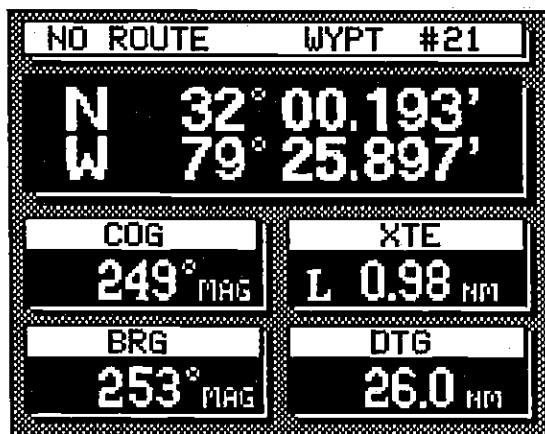

POSITION DISPLAY

## Navigation Display

This screen shows all major navigation information. The displays are as follows:

1. Present Position.
2. Distance To Go (DTG)
3. Time To Go (TTG)
4. Time Of Day (TOD)
5. Altitude (ALT)
6. Speed Over Ground (SOG)
7. Velocity Made Good (VMG)
8. Course Over Ground (COG)
9. Bearing to waypoint (BRG)
10. Cross Track Error (XTE)

Present position is your location in latitude/longitude coordinates. This is expressed as degrees, minutes, and thousandths of a minute. Cross Track Error (XTE) is the distance to the left or right of the course to a waypoint. In other words, if you draw a

## IMPORTANT!

Turning the arrival alarm off prevents the GlobalNav from sequencing to the next waypoint in the route. This, in effect, turns the route off.

## CANCELING A ROUTE

To stop the GlobalNav in a route, press the MENU key, then press the key adjacent to the "Route Planning" label. Now press the key adjacent to the "Cancel Route" label. This stops the GlobalNav from sequencing to any waypoints after the current waypoint. The unit will continue to show navigation information to the current waypoint until the arrival alarm sounds, even though the route was canceled.

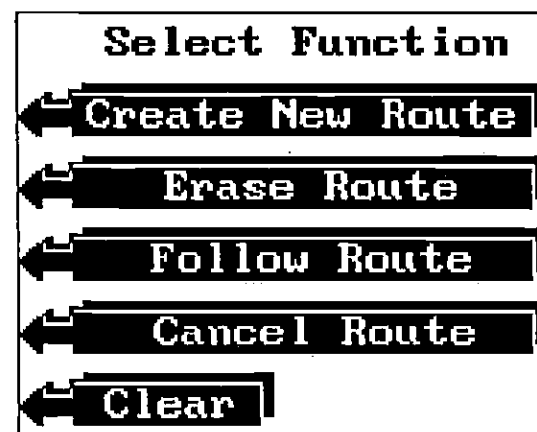

## NOTE:

Canceling a route does not erase the route from memory. It merely stops the GlobalNav from sequencing through the waypoints in the route.

## ERASING A ROUTE

To erase a route from memory, first press the MENU key, then press the key next to the "More" label. Now press the key next to the "Route Planning" label. Next, press the key adjacent to the "Erase Route" label. The screen shown below appears. Use the keys adjacent to the up or down labels to move the box to the desired route name. Then press the key adjacent to the "Erase" label. This erases the route from memory. Press the CLEAR key to exit this menu.

SEL. WAYPT. FOR ROUTE: WRECK	<b>Waypt # 1</b> N 32°24.142' W 80°18.357' DTG: 32.24NM BRG: 239°M
← <b>Enter</b>	<b>WAYPT # 1</b>
← <b>Up</b>	WAYPT # 2
← <b>Down</b>	WAYPT # 3
← <b>Clear</b>	WAYPT # 4
	WAYPT # 5
	WAYPT # 6
	WAYPT # 7

NO ROUTE		WYPT #21	
<b>N 32° 08.193'</b>		<b>W 79° 25.897'</b>	
DTG	8.33 NM	ALT	+8 FT
TTG	0:13:15	SOG	27.5 KNT
TOD	10:28 AM	VMG	28.1 KNT
COG	254° M	BRG	258° M
		XTE	L 0.23 FT

NAVIGATION DISPLAY

Finally, the "Select Route Travel Direction" menu appears as shown below. This is the last route menu. You can follow a route forward or backward. In our example route, starting at waypoint number 5, travelling forward would take us to waypoints 6, 7, 8, 9, and 10. Travelling backward would take us to waypoints 4, 3, 2, and 1. Press the key next to the label showing the desired direction.

<b>Select Route Travel Direction</b>	
← <b>Forward</b>	
← <b>Reverse</b>	
← <b>Clear</b>	

The GlobalNav now shows navigation to the first waypoint on the route. The arrival alarm sounds when you reach each waypoint for about seven seconds. It's radius is preset for 0.1 mile. In other words, the arrival alarm sounds when you come within .1 nautical mile of the waypoint. When you reach the last waypoint in the route, the arrival alarm sounds until you turn it off.

straight line from your starting position to the destination, any deviation to the left or right of that line is your cross track error. Time To Go (TTG) is the time it will take you to reach the destination, travelling at your present speed. Time Of Day (TOD) is the current time. Distance To Go (DTG) is the distance from your present position to the destination. Altitude (ALT) is your height above sea level. Speed Over Ground (SOG) is the actual speed you are travelling. Velocity Made Good (VMG) is the speed you are travelling towards the destination. Bearing to waypoint (BRG) is the direction from your present position to the destination measured in degrees. Course Over Ground (COG) is the direction the boat is travelling.

Remember ,Cross Track Error, Distance To Go, Time To Go, Velocity Made Good, and Bearing are used only when a waypoint is recalled.

### Steering Screen

This screen shows a graphical display of your present position, Cross Track Error, and Track. (Track is your path you've travelled.) At the top of the screen, the route name (if in use) and waypoint number are displayed. Next, Course Over Ground (COG), Distance To Go (DTG), Bearing (BRG) and Cross Track Error (XTE) display. Only Course Over Ground is used if a waypoint is not recalled.

The CDI (Course Deviation Indicator) displays in the middle of the screen. The straight line down the middle of the display is the Bearing Line. This is the shortest distance to the waypoint

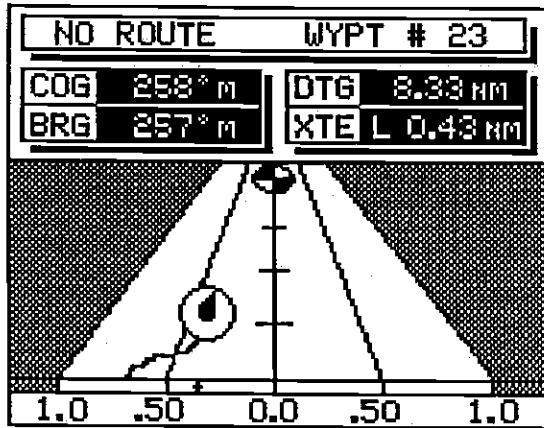

STEERING DISPLAY

Angled lines on the left and right of the Bearing Line measure the cross track error. The cross track error (XTE) range shows at the bottom of the screen. This scale has marks that match the angled lines. This lets you know the cross track error. A small "+" moves with your present position above the scale to help you determine the cross track error. In the example above, the cross track error is .43 miles to the left of course. The small "+" is slightly to the right of the .50 scale mark on the XTE range. This scale is adjustable (see below).

Your present position is shown by the circle with an arrow inside. The arrow shows the direction the boat is heading (COG). If you are left of course, then you need to steer the boat to the right to get back on course. The solid line extending from the circle is your track. To travel directly to a waypoint, try to keep the circle on the center line. The waypoint is depicted by another circle at the top of the CDI display (if it's within the steering screen's range.) As you approach the waypoint, the two circles will move closer together. If the waypoint is not displayed on the screen, a small arrow will appear at either the top of the screen or the bottom pointing the way to the waypoint. Using the digital displays at the top of the screen along with the graphical display at the bottom lets you accurately steer the boat to a waypoint.

### STEERING SETUP

The Steering Setup menu lets you change the XTE range and erase the track line on the steering display. To do this, press the MENU key, then press the key adjacent to the "Steering Setup" label. The screen shown at the top of the next page appears.

then 1, and finally 5. In this case, you must select waypoint 3, 1, and 5 in that order when making the route.

After you've selected all of the waypoints for the route, press the "CLEAR" key. Your new route is stored in memory, ready for use.

### FOLLOWING A ROUTE

To follow a route, press the MENU key, then press the key adjacent to the "More" label. Next, press the key adjacent to the "Route Planning" label. Finally, press the key next to the "Follow Route" label. The screen shown below appears. The "Select Route" menu has the list of routes on the screen's right side. Press the key next to the up or down labels until the box is around the desired route. Then press the key next to the "Enter" label. This tells the GlobalNav which route to follow.

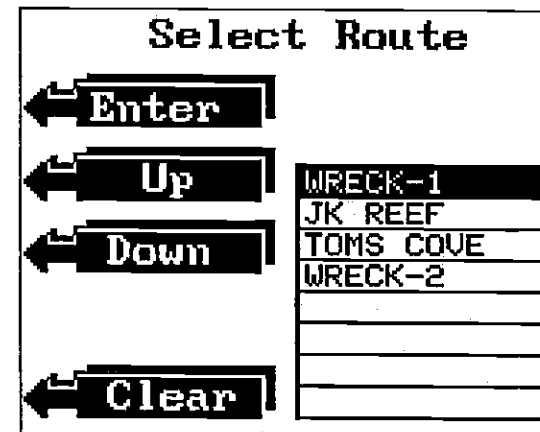

The starting waypoint menu automatically appears as shown at the top of the next page. You must tell the unit which waypoint in the route to go to first. The route can start at any waypoint in the route. For example, suppose you have a route consisting of waypoints one through ten in consecutive order. You can start at waypoint number 5, if desired. The GlobalNav will give navigation data to waypoint number 5 first. When you reach number 5 and the arrival alarm sounds, the GlobalNav will sequence to waypoint number 6. It will continue in this manner until you reach waypoint number 10.

To spell the route's name, use the keys next to the left and right labels to move the box to the desired letter. Now press the key adjacent to the "Select" label. The selected letter appears at the top of the screen under the "ENTER NAME:" message. To erase the last letter, press the key next to the "Backsp." label. Each time you press this key, the letter at the end of the line will be erased.

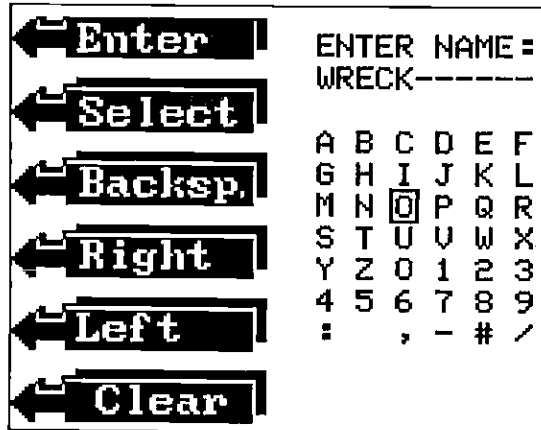

For example, to name a new route "WRECK," move the box to the "W," then press the key next to the "Select" label. The letter "W" appears at the top of the screen. Now move the box to the "R" and press the key next to the "Select" label again. Repeat until the word "WRECK" shows at the top of the screen. Now press the key adjacent to the "Enter" label. This names the route and the GlobalNav automatically displays the select waypoint menu as shown below.

The Select Waypoint For Route menu works the same as the View and Save Waypoint menu. Move the box that surrounds waypoint number one up or down until it's on the first waypoint in the route. Press the key next to the "Enter" label. This selects the waypoint. Move the box to the next waypoint in the route and select it in the same manner. Continue doing this until all waypoints in the route are selected.

**IMPORTANT!**

You must select waypoints in the order they are to be used in the route. In other words, suppose you want a route that consists of waypoint numbers 1, 3, and 5. But you wish to travel to 3 first.

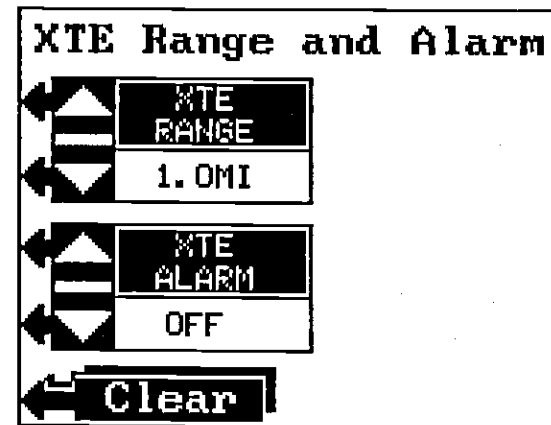

The XTE Range adjustment menu is at the top of the screen, the Clear Trail menu is beneath it. To change the XTE range, press the key adjacent to the up or down arrow to increase or decrease it. The range is adjustable from 0.1 to 10 miles. When the unit is turned on for the first time, or after it's preset, the XTE range is 1.0 mile.

The "Clear Trail" label also appears on this menu. Press the key adjacent to this label to erase the track line.

See the "Alarms" section for information on the CDI alarm.

**Status Display**

This screen shows the state of each satellite the unit is tracking. To view this screen, press the MENU key, then press the key next to "Status Display." The screen shown below appears.

NO ROUTE		WYPT #21			
N 32°00.193' W 79°25.865'					
GDOF	5.37	FIX	5 (20)		
HDOF	1.25	ALT	+5 FT		
SAT	PRN	TRK	ELV	AZM	SNR
1	7	T	54°	330°	43
2	11	T	45°	188°	50
3	15	S	15°	212°	10
4	18	T	73°	285°	36
5	24	S	30°	289°	21

Your present position appears near the top of the screen. Beneath this and to the left are the GDOP and HDOP displays. GDOP stands for Geometric Dilution Of Precision. This is a crossing angle indicator. It shows the combination value of horizontal (HDOP), vertical (VDOP), and Time (TDOP). The smaller the GDOP number is, the better the crossing angles are. The GPS receiver selects satellites based on GDOP, therefore it always tries to use satellites that will result in good crossing angles. The best way to use GDOP is to anticipate system problems. In other words, if the crossing angles are decreasing, then the satellites are moving out of your viewing range. Therefore, the system may become unusable if more satellites don't appear shortly. By monitoring the GDOP display, you can foresee system geometry problems before they happen.

NO ROUTE		WYPT #21			
N 32°00.193' W 79°25.895'					
GDOP	5.37	FIX	5 (20)		
HDOP	1.25	ALT	+5 FT		
SAT	PRN	TRK	ELV	AZM	SNR
1	7	T	54°	330°	43
2	11	T	45°	168°	50
3	15	S	15°	212°	10
4	18	T	73°	265°	36
5	21	S	30°	22°	21

Beneath the GDOP display is the HDOP display. This shows the 2D, horizontal crossing angle. Again, the smaller the number is, the better the crossing angles are.

Observe both the GDOP and HDOP displays when the system is working well and when it isn't. This will give you an idea of what the numbers should be during those times.

To the right of the GDOP display is the Fix display. Fix shows how well the unit is tracking satellites. The best fix number is one, the worst is 9. As the fix number increases, the position's "jitter" increases. Jitter is the small position changes around a location. In other words, if you place a GPS receiver on the ground and turn it on, you'll see the position "jump around." Very small position changes will constantly occur. This is called jitter;

There are four steps required to create and follow a route. First, you must create and name the route. Next, select the waypoints used in the route. Then determine the starting waypoint. Now tell the unit to follow the route. Finally, the unit will ask you if you wish to run the route forward or backward. After these steps are completed, the GlobalNav will start on the route.

## CREATING A ROUTE

To create a route, first press the MENU key. Next, press the key adjacent to the "More" label. Now press the key adjacent to the "Route Planning" label. The screen shown below appears. Finally, press the key adjacent to the "Create New Route" label. The screen shown at the bottom of this page appears. This screen lets you enter the name of the route. The route name can have up to ten characters.

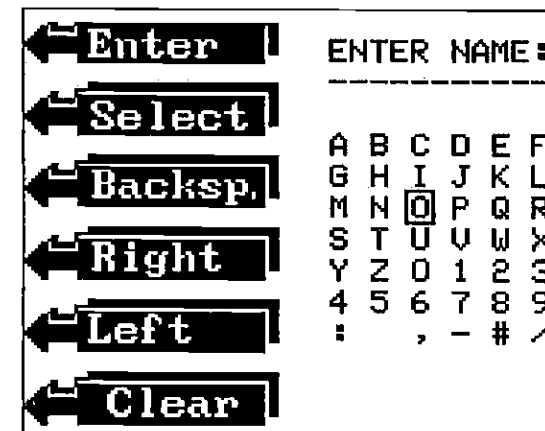
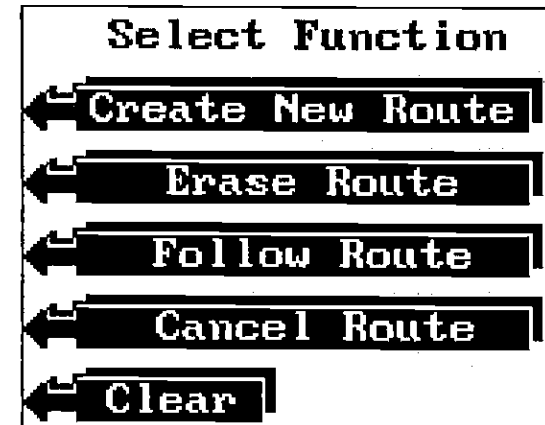

## Destination Waypoint Number

The Destination Waypoint Number menu gives you another way to recall a waypoint.

To use this feature, first press the Waypoint Recall key. Now press the key adjacent to the "Dest. Waypt Num" label. The menu shown below appears.



Simply press the key adjacent to the number of the destination waypoint. For example, if you want to recall waypoint number 10, press the 1 and the 0 keys. Finally, press the key adjacent to the Enter key. The GlobalNav will immediately show navigation information to the recalled waypoint on the GPS screens.

## ROUTES

Routes gives you the ability to navigate to several waypoints without having to re-program the unit after arriving at each one. A route consists of two or more waypoints. When you run a route, the GlobalNav gives navigation information to the first waypoint in the route. When you reach the first waypoint (signalled by the Arrival Alarm), the GlobalNav automatically sequences to the next waypoint. Navigation information is shown to this waypoint and the process repeats. When the last waypoint in a route is reached, the arrival alarm sounds until it's turned off.

it's normal and happens in all electronic navigation devices. If the fix number and HDOP numbers are good, then the latitude/longitude position shown on the display should be good, excluding the effect of S/A. Also shown in the fix box is the mode display, shown in parenthesis. "2D" means the unit is showing position only. "3D" means it's showing both position and altitude data. "H" stands for Altitude Hold.

Beneath the fix box is the Altitude display. This is your height above sea level in feet.

The box at the bottom of the screen shows the status of each receiver channel. Channels one through five are listed on the far left side of the screen. Four channels track each track one satellite (if available). The fifth channel switches between all satellites in view to track ones not being used to determine position. The satellite number (sometimes called the PRN number) the channel is tracking shows in the SAT column. TRK is the "Track" column. An "S" in this column means the receiver is searching for the satellite. "T" means it's tracking the satellite. If the box is blank, no action is being taken by that receiver's channel. ELV is the elevation of the satellite above the horizon in degrees. AZM is the satellite's azimuth, or direction from your position in degrees. SNR is the signal to noise ratio for the satellite. The larger the SNR number, the better. The highest SNR we've seen so far is 52. Typically, any number in the forties is a good SNR.

## PLOTTER

The plotter screen shows a "birds-eye" view of your present position, course, and direction of travel. If you've recalled a waypoint, the starting position and destination also show.

To use the plotter, simply press the PLOTkey. A screen similar to the one at right appears.

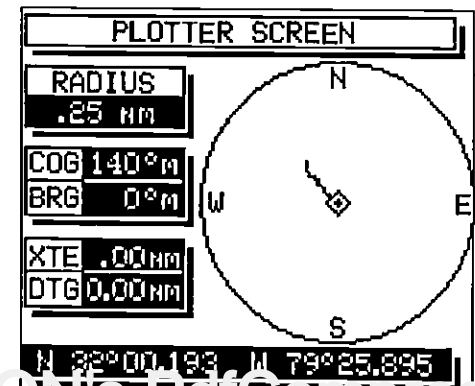

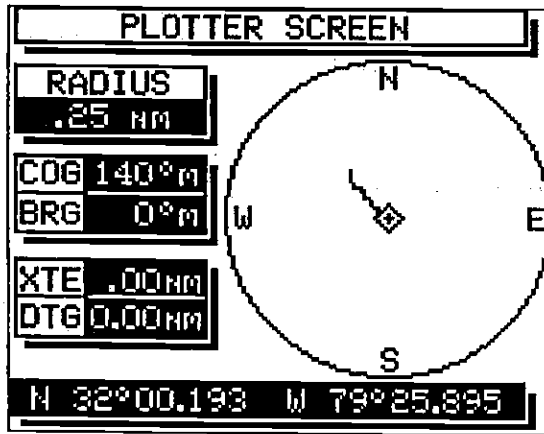

The diamond is your present position. The solid line is your track, or path you've travelled. The circle is a compass rose with north, south, east, and west marked.

The plotter's radius shows at the top left corner of the screen. This is the distance from the center of the circle to the edge. The plotter's radius is .25 nautical mile when the unit is first turned on or when it's preset. See the Plotter Radius section for information on changing the radius.

Beneath the radius display are the Course Over Ground, Bearing, Distance To Go, and Cross Track Error displays. These are used only when a waypoint is recalled. Present position in latitude/longitude displays at the bottom of this screen.

### Using the Plotter with a Waypoint

You can see your present position, starting position, and destination when you recall a waypoint. To use the plotter in this manner, simply recall a waypoint (see the Waypoint Recall section), then press the PLOTTER key. A screen similar to the one at the top of the next page appears.

The square box with a "S" is your starting location. This is your position when the waypoint is recalled. The diamond is your present position, and the circle with the "D" is the destination. The destination is the position of the recalled waypoint. If you are travelling on a route, it's the first waypoint on the route. The dotted line is the shortest path to the destination from the starting location. Follow this line to get to the waypoint. The solid line is your track, or path you've travelled.

There are two choices in recalling a waypoint. You can use the "View/Go To Waypoint" method, which is identical in operation to the Waypoint Save's "View/Save" menu. The other option is the Destination Waypoint Number in which you simply enter the waypoint number that is your desired destination.

The other two options on this screen lets you view the currently recalled waypoint (View Current Wpt) or cancel the navigation to the current waypoint (Cancel Waypt. Nav.)

### VIEW/GO TO WAYPOINT

To select a destination waypoint from the list of stored waypoints, first press the WAYPOINT RECALL key. Now press the key adjacent to the "View/Go To Waypt" label. The screen shown below appears.

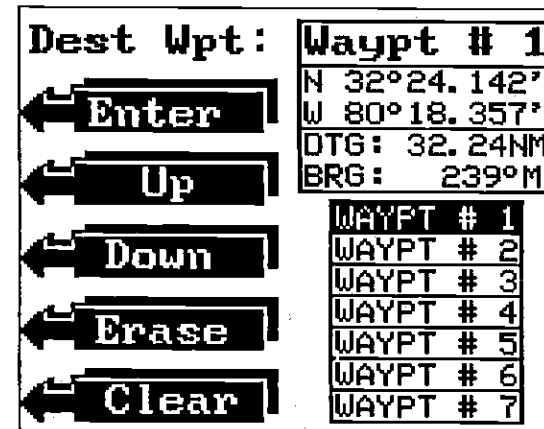

At the screen's upper right corner is the waypoint number currently displayed. The position for this waypoint is shown directly beneath the waypoint number. Distance to the waypoint and bearing to the waypoint from your present position show under the position. The first seven waypoint numbers are listed at the bottom of the screen. This is the waypoint selection box. Waypoint number one is shown in reverse. To select a different waypoint number, press the key adjacent to the up or down labels. As the black box moves to each waypoint number, the waypoint's location, distance to go, and bearing display at the top of the screen. Move the black box to the desired waypoint number, then press the key adjacent to the Enter label to recall the waypoint. The GlobalNav will immediately show navigation information to the recalled waypoint on the GPS screens.

## GO TO WAYPOINT

The GlobalNav gives you the option to enter a position and go to it without storing it in the unit's memory.

**Save Waypoint:**  
N 32°09.264'  
W 80°37.408'

← **Go to Waypoint**

← **More**

← **Clear**

To go to a waypoint without saving it, first enter a position using the "New Waypoint Position" method described earlier. Next, press the key adjacent to the "More" label until the "Go To Waypoint" label appears. Now simply press the key adjacent to this label. The GlobalNav will immediately show navigation data to this position.

## WAYPOINT RECALL

You must recall a waypoint in order to use the navigation features of the GlobalNav. To recall a waypoint, first press the WAYPOINT RECALL key. The screen shown below appears.

**Select Function**

← **View Current Wpt**

← **View/Go To Waypt**

← **Dest. Waypt Num.**

← **Cancel Waypt Nav.**

← **Clear**

**NO ROUTE** **WYPT # 21**

**RADIUS**  
.25 NM

**COG** 230°M  
**BRG** 237°M

**XTE** 0.2NM  
**DTG** 3.33NM

N  
W E S

**N 32°00.193 W 79°25.895**

## PLOTTER MENUS

Pressing the MENU key, then the key adjacent to the "Plotter Setup" gives you a new set of menus which relate only to the plotter. A description of the plotter menus follow.

← **↑** **FLPOTTER**  
← **↓** **RADIUS**

← **↑** **.25NM**

← **↑** **UPDATE**  
← **↓** **INTERVAL**

← **↑** **2 SECONDS**

← **Clear Plot Trail**

← **Clear**

## PLOTTER RADIUS

Radius menu lets you change the circle's radius. The circle's radius is .25 nautical mile when the GlobalNav is first turned on or preset. To change the radius, press the key adjacent to the up arrow to increase the radius or the down arrow to decrease it. Press the CLEAR key when finished.

## UPDATE INTERVAL

The plotter shows your track by drawing a solid line behind your present position. When the unit is turned on for the first time, the position is updated once every ten seconds. This time is variable from two seconds to ten minutes.

The plotter has 200 dots available to plot your track on the screen. As each dot is placed at your last location, one is erased from the end of the line. You can use up all 200 dots if you plot a course to a destination that's a long distance away. This is especially true if you use a short plotter update time.

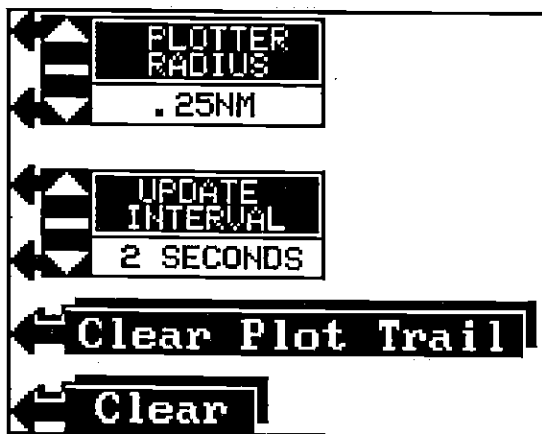

To keep a continuous line plotted, you may want to experiment with the update interval. Lengthening the interval between plots gives you a better chance to see more history.

To change the plotter update time, press the key adjacent to the up arrow to increase the time between plots or the down arrow to decrease it. Press the CLEAR key when finished.

## CLEAR PLOT TRAIL

To erase the track line from the display, press the key adjacent to the "Clear Plot Trail" label. The GlobalNav returns to the plotter, erases the track line(s) and centers your present position. As you travel, the plotter continues to draw your new track line.

the key adjacent to the More label. Now press the key adjacent to the "New Waypt. Num." label. The menu below appears.

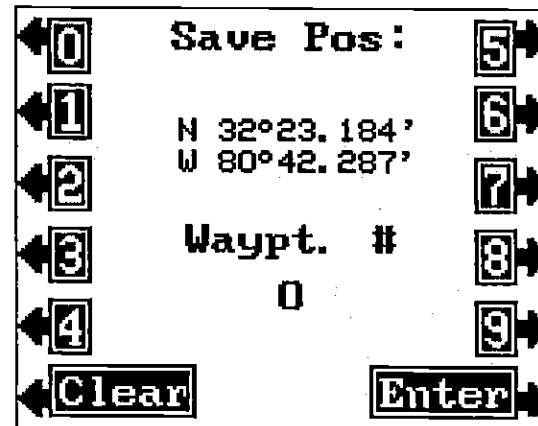

Simply press the key adjacent to the waypoint number(s) that you wish to assign the position shown at the top of the screen. For example, if you want to save the position as waypoint number 10, press the 1 and the 0 keys. Finally, press the key adjacent to the Enter key. The GlobalNav stores that position as waypoint number 10 and returns to the last used screen.

## IMPORTANT!

Remember, the New Waypoint Number method will let you save a position under a waypoint number that is already in use. Make certain you are using the correct waypoint numbers before using this method!

## ERASE A WAYPOINT

To erase a position from the waypoint list, press the Waypoint Save key, then press the key adjacent to the "View/Save Waypt." label. Use the up and down arrow keys to select the waypoint number that you wish to erase. When the desired waypoint number is selected, press the key adjacent to the Erase label. This deletes the position from that waypoint number, leaving it blank. Press the CLEAR key to exit from this menu.

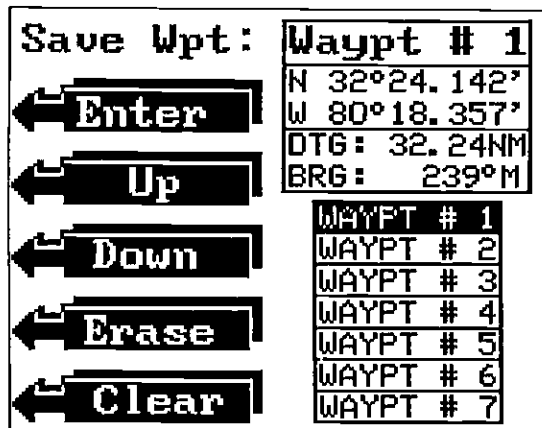

At the screen's upper right corner is the waypoint number currently displayed. The position for this waypoint is shown directly beneath the waypoint number. Distance to the waypoint and bearing to the waypoint from your present position show under the position. The first seven waypoint numbers are listed at the bottom of the screen. This is the waypoint selection box. Waypoint number one is shown in reverse. To select a different waypoint number, press the key adjacent to the up or down labels. As the black box moves to each waypoint number, the waypoint's location, distance to go, and bearing display at the top of the screen. Move the black box to the desired waypoint number, then press the key adjacent to the Enter label to save the position. The position is now saved.

### NOTICE!

The GlobalNav won't let you save a position in a waypoint location that's already in use when you use the Waypoint QuickSave feature. However, it will let you overwrite a position when using the View and Save or the New Waypoint Number (see below) methods. Use caution when saving a position. Make certain the waypoint number is really the one you wish to use.

### New Waypoint Number

The New Waypoint Number menu gives you another way to save a waypoint. This option lets you simply enter the number of the waypoint that you want the position assigned to.

To use this feature, first enter a position, or use your present position by merely pressing the Waypoint Save key. Next, press

### HOW TO SAVE A WAYPOINT

Waypoints are locations that you store in the GlobalNav's memory. You can then navigate to these locations using the Steering, Navigation, or Plotter displays. Waypoints are useful for marking shipwrecks, buoys, and other fishing or navigational positions. The GlobalNav can store up to 75 waypoints. You can store your present position as a waypoint or enter latitude/longitude positions as waypoints.

#### Saving Current Position (Waypoint Quick Save Method)

The GlobalNav lets you instantly save your present position as a waypoint. This "Quick Save" feature permits the storage of a wreck's position or other fishing and navigational positions quickly and easily.

To save your present position, simply press the WAYPOINT QUICKSAVE key. The GlobalNav immediately stores your present position in the first available empty waypoint location. (Waypoint locations are numbered 1 through 75.) A message appears at the top of the screen: "SAVED AS #1." This lets you know the waypoint number assigned to the position you just saved. To return to that waypoint, see the Waypoint Recall section.

#### Saving Current Position (Save as # Method)

This method is similar to the Quick Save method, except it allows you to view the waypoint number before the GlobalNav automatically saves it. To save a position using this method, first press the WAYPOINT SAVE key. The screen shown at the top of the next page appears. The position to be saved appears at the top of the screen. This is your position at the time you pressed the WAYPOINT SAVE key. Immediately beneath this position is a label that says "Save as #." The number in this label is the first available empty waypoint number. Simply press the key adjacent to this label to save the position at the top of the screen under the waypoint number listed on the label. The GlobalNav returns to the last used screen.

## Enter New Waypoint

To save a position other than your present one, first press the WAYPOINT SAVE key. Next, press the key adjacent to the More label. The screen shown below appears.

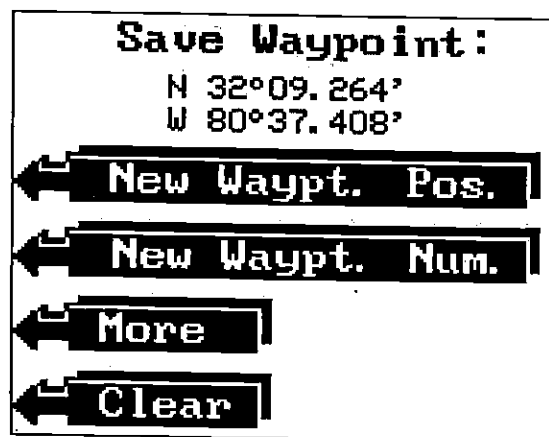

Save Waypoint:  
N 32°09.264'  
W 80°37.408'

← New Waypt. Pos. →

← New Waypt. Num. →

← More →

← Clear →

Now press the key adjacent to the "New Waypt. Pos." label. The screen shown below appears.

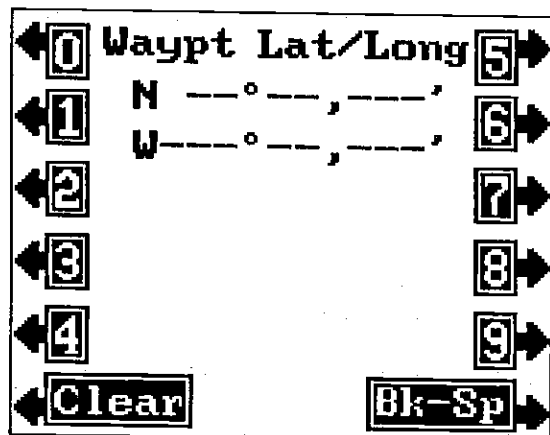

Waypt Lat/Long

← 0 → N ---°---', ---'

← 1 → W ---°---', ---'

← 2 →

← 3 →

← 4 →

← Clear →

← 5 →

← 6 →

← 7 →

← 8 →

← 9 →

← Blk-Sp →

Now enter the position you wish to save as a waypoint. Remember to enter the position in degrees, minutes, and thousands of a minute. Also, if the position is less than 100 degrees longitude, add a zero to it. For example, if the longitude is 80 degrees, then enter 080. After entering the last number, the screen shown at the top of the next page appears.

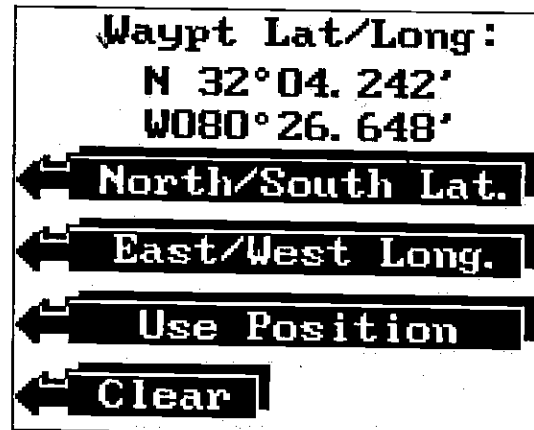

Waypt Lat/Long:  
N 32°04.242'  
W080°26.648'

← North/South Lat. →

← East/West Long. →

← Use Position →

← Clear →

Press the key adjacent to the "East/West Long." to switch the longitude from west to east, if necessary. When the correct position is shown, press the key adjacent to the "Use Position" label. To exit from this screen without saving the position, press the CLEAR key.

The GlobalNav returns to the Save Waypoint screen (shown at the top of the previous page) after you press the key adjacent to the "Use Position" label. The position you entered shows at the top of the screen. To save this position, press the key adjacent to the "Save as #" label as described above or press the key adjacent to the "View/Save Waypt." label. Information on this menu selection follows.

### IMPORTANT!

You haven't saved the waypoint yet! You will lose the position if you press the key adjacent to the "CLEAR" label. See the "Save as #" or "View and Save Waypoint" section to save this position.

### View and Save Waypoint

The View and Save Waypoint screen lets you see the list of saved waypoints. You can then choose the waypoint number to save the position or erase a position from the waypoint list.

To save your present position as a waypoint using this method, first press the Waypoint Save key. Then press the key adjacent to the "View/Save Waypt." label. The screen shown at the top of the next page appears.